



An Algebraic and Graphical Calculus for Quantum Processes

Samson Abramsky

<http://web.comlab.ox.ac.uk/oucl/work/samson.abramsky/>

Oxford University Computing Laboratory



Overview



Overview

- ▲ “Information is Physical”: we must take seriously the fact that information processing systems are *physically embodied*, hence ultimately quantum-mechanical in nature.



Overview

- ▲ “Information is Physical”: we must take seriously the fact that information processing systems are *physically embodied*, hence ultimately quantum-mechanical in nature.
- ▲ Equal and opposite reaction: we can (and must and will) look at physical systems, qua information processing systems, with the same concepts and methods which have proved centrally important in Computer Science.



Overview

- ▲ “Information is Physical”: we must take seriously the fact that information processing systems are *physically embodied*, hence ultimately quantum-mechanical in nature.
- ▲ Equal and opposite reaction: we can (and must and will) look at physical systems, qua information processing systems, with the same concepts and methods which have proved centrally important in Computer Science.
- ▲ Current state of the art in quantum computation and information: “hacking with qubits”.
Wanted: high-level languages, abstraction principles, powerful methods for specification, design and verification.



Overview

- ▲ “Information is Physical”: we must take seriously the fact that information processing systems are *physically embodied*, hence ultimately quantum-mechanical in nature.
- ▲ Equal and opposite reaction: we can (and must and will) look at physical systems, qua information processing systems, with the same concepts and methods which have proved centrally important in Computer Science.
- ▲ Current state of the art in quantum computation and information: “hacking with qubits”.
Wanted: high-level languages, abstraction principles, powerful methods for specification, design and verification.
- ▲ In recent work with Bob Coecke, we have developed a high-level approach to quantum computation and information, based on a novel axiomatization of the mathematical structure of QM.



Overview

- ▲ “Information is Physical”: we must take seriously the fact that information processing systems are *physically embodied*, hence ultimately quantum-mechanical in nature.
- ▲ Equal and opposite reaction: we can (and must and will) look at physical systems, qua information processing systems, with the same concepts and methods which have proved centrally important in Computer Science.
- ▲ Current state of the art in quantum computation and information: “hacking with qubits”.
Wanted: high-level languages, abstraction principles, powerful methods for specification, design and verification.
- ▲ In recent work with Bob Coecke, we have developed a high-level approach to quantum computation and information, based on a novel axiomatization of the mathematical structure of QM.
- ▲ The formalism can be developed in an appealing graphical calculus, which has strong links to recent work at the interface between Geometry and Physics. (Temperley-Lieb algebra, Jones polynomial and other invariants, TQFT’s etc.)



Bits and Qubits

Bits:

- ▲ have two values 0, 1
- ▲ are freely readable and duplicable
- ▲ admit arbitrary data transformations



Bits and Qubits

Bits:

- ▲ have two values 0, 1
- ▲ are freely readable and duplicable
- ▲ admit arbitrary data transformations

Qubits:

- ▲ have a 'sphere' of values spanned by $|0\rangle$, $|1\rangle$

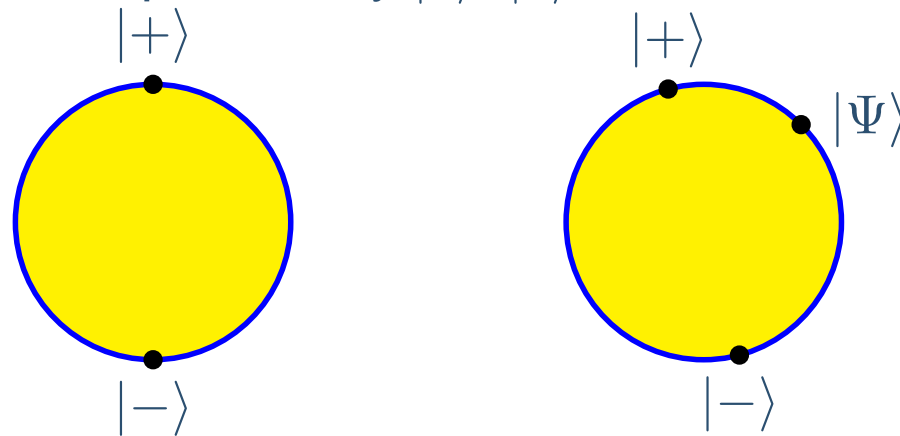

- ▲ measurements of qubits

- have two outcomes $|-\rangle$, $|+\rangle$
- change the value $|\psi\rangle$

- ▲ admit *unitary transformations*, i.e. antipodes and angles are preserved.



'Truth makes an angle with reality'

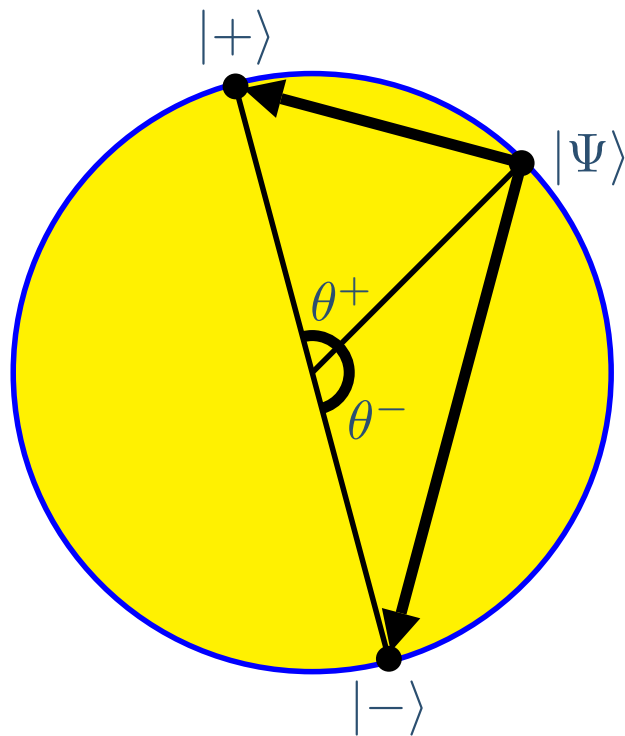

We have *partial constant maps* $Q \rightarrow Q$ on the sphere Q

$$\mathbf{P}_+ : |\psi\rangle \mapsto |+\rangle \quad \mathbf{P}_- : |\psi\rangle \mapsto |-\rangle$$

which have chance $\text{prob}(\theta^\#)$ for $\# \in \{+, -\}$.
We know the value *after* the measurement, but not what the qubit was *before* the measurement!

So measurements change the state, and apparently lose information. This seems like bad news! However ...



Quantum Entanglement

- ▣ Title
- ▣ Overview

Introduction to Quantum
Mechanics

Entanglement

- ▣ Quantum Entanglement
- ▣ From 'paradox' to 'feature':
 - Teleportation
- ▣ Symmetric leadership election
- ▣ Entanglement: where does the magic come from?
- ▣ Entangled states as linear maps
- ▣ Some notation for projectors
- ▣ On the trail of structure
- ▣ What is the output?
- ▣ Follow the line!
- ▣ Teleportation: basic case
- ▣ Teleportation: general case
- ▣ Logic-Gate Teleportation
- ▣ Entanglement Swapping
- ▣ The Logic of Lines
- ▣ Sets and Relations have the same structure!

Categorical Quantum
Mechanics

The Graphical Calculus

Bell state:

$$|00\rangle + |11\rangle$$



EPR state:

$$|01\rangle + |10\rangle$$





Quantum Entanglement

- ▣ Title
- ▣ Overview

Introduction to Quantum Mechanics

Entanglement

- ▣ Quantum Entanglement
- ▣ From 'paradox' to 'feature': Teleportation
- ▣ Symmetric leadership election
- ▣ Entanglement: where does the magic come from?
- ▣ Entangled states as linear maps
- ▣ Some notation for projectors
- ▣ On the trail of structure
- ▣ What is the output?
- ▣ Follow the line!
- ▣ Teleportation: basic case
- ▣ Teleportation: general case
- ▣ Logic-Gate Teleportation
- ▣ Entanglement Swapping
- ▣ The Logic of Lines
- ▣ Sets and Relations have the same structure!

Categorical Quantum Mechanics

The Graphical Calculus

Bell state:

$$|00\rangle + |11\rangle$$



EPR state:

$$|01\rangle + |10\rangle$$



Compound systems are represented by *tensor product*:

$\mathcal{H}_1 \otimes \mathcal{H}_2$. Typical element:

$$\sum_i \lambda_i \cdot \phi_i \otimes \psi_i$$

Superposition encodes *correlation*. Einstein's 'spooky action at a distance'. Even if the particles are spatially separated, measuring one has an effect on the state of the other.

Bell's theorem: QM is *essentially non-local*.



From 'paradox' to 'feature': Teleportation

- ◻ Title
- ◻ Overview

Introduction to Quantum Mechanics

Entanglement

- ◻ Quantum Entanglement
- ◻ From 'paradox' to 'feature': Teleportation
- ◻ Symmetric leadership election
- ◻ Entanglement: where does the magic come from?
- ◻ Entangled states as linear maps
- ◻ Some notation for projectors
- ◻ On the trail of structure
- ◻ What is the output?
- ◻ Follow the line!
- ◻ Teleportation: basic case
- ◻ Teleportation: general case
- ◻ Logic-Gate Teleportation
- ◻ Entanglement Swapping
- ◻ The Logic of Lines
- ◻ Sets and Relations have the same structure!

Categorical Quantum Mechanics

The Graphical Calculus

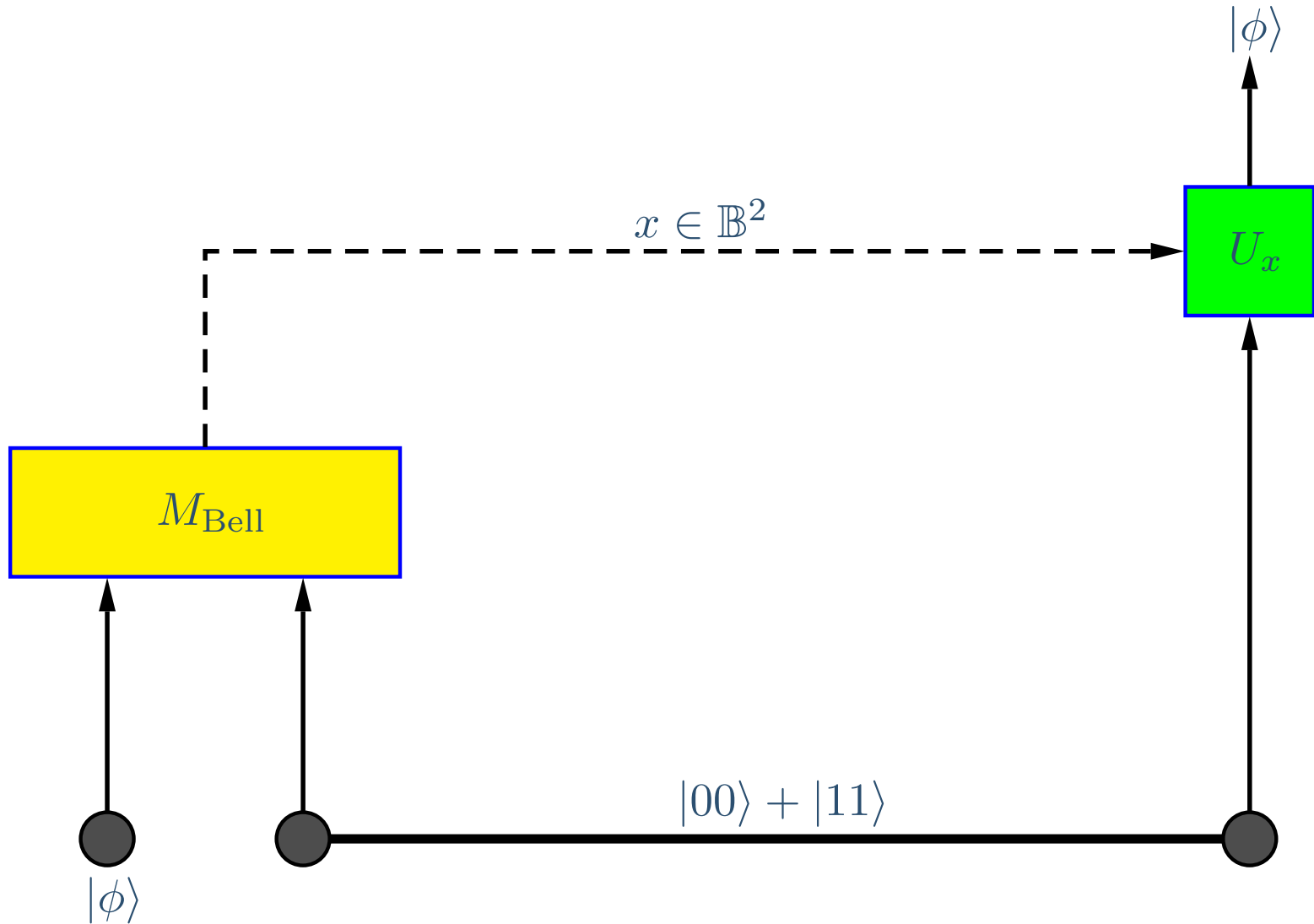



Symmetric leadership election

- ◻ Title
- ◻ Overview

Introduction to Quantum
Mechanics

Entanglement

- ◻ Quantum Entanglement
- ◻ From 'paradox' to 'feature':
Teleportation
- ◻ Symmetric leadership
election
- ◻ Entanglement: where does
the magic come from?
- ◻ Entangled states as linear
maps
- ◻ Some notation for
projectors
- ◻ On the trail of structure
- ◻ What is the output?
- ◻ Follow the line!
- ◻ Teleportation: basic case
- ◻ Teleportation: general case
- ◻ Logic-Gate Teleportation
- ◻ Entanglement Swapping
- ◻ The Logic of Lines
- ◻ Sets and Relations have
the same structure!

Categorical Quantum
Mechanics

The Graphical Calculus

Consider the W state:

$$|100\rangle + |010\rangle + |001\rangle$$

(Generalizes to n factors).

The W state is prepared, and the i 'th qubit given to the i 'th agent. Each agent asynchronously and independently measures its own qubit. Exactly one agent will measure 1!

To complete the protocol, the 'winner' sends its number classically to the other agents.



Entanglement: where does the magic come from?

A pair of qubits is *not* described by a pair

$$|\psi_1, \psi_2\rangle \in Q \times Q$$

but by a *linear function*

$$|f : Q \rightarrow Q\rangle \in Q \otimes Q$$

This follows from the isomorphism (in finite dimensions)

$$\mathcal{H}_1 \otimes \mathcal{H}_2 \simeq \mathcal{H}_1 \circlearrowleft \mathcal{H}_2.$$



Entangled states as linear maps

Indeed, $\mathcal{H}_1 \otimes \mathcal{H}_2$ is spanned by

$$\begin{array}{ccc} |11\rangle & \cdots & |1m\rangle \\ \vdots & \ddots & \vdots \\ |n1\rangle & \cdots & |nm\rangle \end{array}$$

hence

$$\sum_{i,j} \alpha_{ij} |ij\rangle \longleftrightarrow \begin{pmatrix} \alpha_{11} & \cdots & \alpha_{1m} \\ \vdots & \ddots & \vdots \\ \alpha_{n1} & \cdots & \alpha_{nm} \end{pmatrix} \longleftrightarrow |i\rangle \mapsto \sum_j \alpha_{ij} |j\rangle$$

Pairs $|\psi_1, \psi_2\rangle$ are a special case — $|ij\rangle$ in a well-chosen basis.



Some notation for projectors

- ◻ Title
- ◻ Overview

Introduction to Quantum
Mechanics

Entanglement

- ◻ Quantum Entanglement
- ◻ From 'paradox' to 'feature':
Teleportation
- ◻ Symmetric leadership
election
- ◻ Entanglement: where does
the magic come from?
- ◻ Entangled states as linear
maps
- ◻ Some notation for
projectors
- ◻ On the trail of structure
- ◻ What is the output?
- ◻ Follow the line!
- ◻ Teleportation: basic case
- ◻ Teleportation: general case
- ◻ Logic-Gate Teleportation
- ◻ Entanglement Swapping
- ◻ The Logic of Lines
- ◻ Sets and Relations have
the same structure!

Categorical Quantum
Mechanics

The Graphical Calculus

A projector onto the 1-dimensional subspace spanned by a vector $|\psi\rangle$ will be written \mathbf{P}_ψ . It is essentially (up to scalar multiples) a “partial constant map”

$$\mathbf{P}_\psi : |\phi\rangle \mapsto |\psi\rangle.$$

This will correspond e.g. to a branch of a (projective, non-degenerate) measurement, or to a preparation.



On the trail of structure

The identity map

$$|\text{id} : Q \rightarrow Q\rangle \in Q \otimes Q \quad |11\rangle + \dots + |nn\rangle \longleftrightarrow |i\rangle \mapsto |i\rangle$$

is the *Bell state*.

A measurement of $Q \otimes Q$ has four outcomes

$$|f_1\rangle, |f_2\rangle, |f_3\rangle, |f_4\rangle \quad (\text{cf. } |00\rangle, |01\rangle, |10\rangle, |11\rangle)$$

and corresponding projectors

$$\mathbf{P}_f : Q \otimes Q \rightarrow Q \otimes Q :: |g\rangle \mapsto |f\rangle$$

E.g. the Bell state is produced by

$$\mathbf{P}_{\text{id}} : Q \otimes Q \rightarrow Q \otimes Q :: |g\rangle \mapsto |\text{id}\rangle$$

Key Question: *Do entangled states qua functions compose (somehow)?*



What is the output?

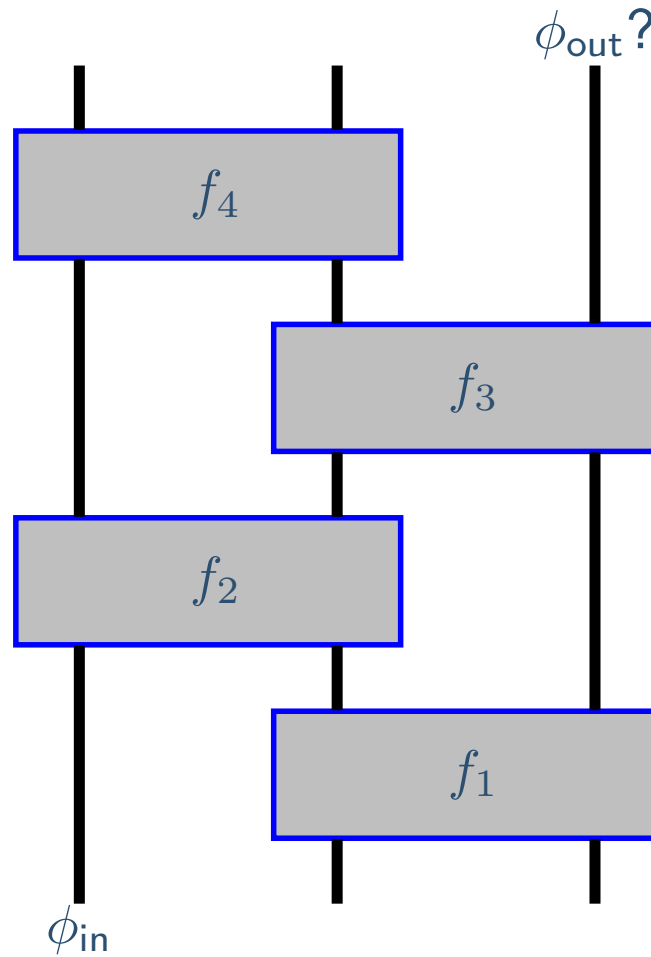

$$(\mathbf{P}_{f_4} \otimes 1) \circ (1 \otimes \mathbf{P}_{f_3}) \circ (\mathbf{P}_{f_2} \otimes 1) \circ (1 \otimes \mathbf{P}_{f_1}) : \mathcal{H}_1 \otimes \mathcal{H}_2 \otimes \mathcal{H}_3 \longrightarrow \mathcal{H}_1 \otimes \mathcal{H}_2 \otimes \mathcal{H}_3$$



What is the output?

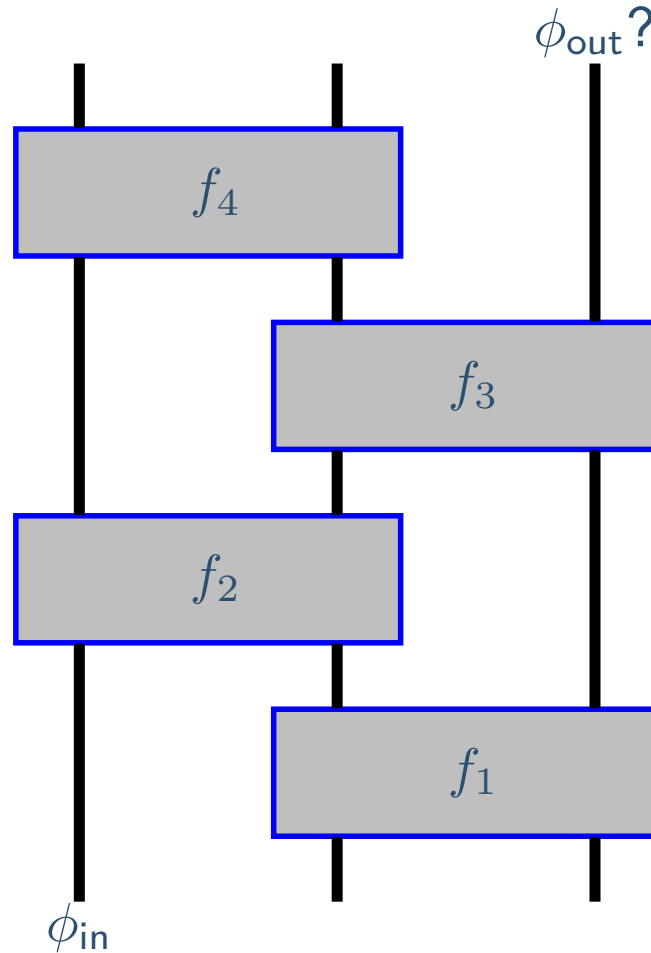

$$(\mathbf{P}_{f_4} \otimes 1) \circ (1 \otimes \mathbf{P}_{f_3}) \circ (\mathbf{P}_{f_2} \otimes 1) \circ (1 \otimes \mathbf{P}_{f_1}) : \mathcal{H}_1 \otimes \mathcal{H}_2 \otimes \mathcal{H}_3 \longrightarrow \mathcal{H}_1 \otimes \mathcal{H}_2 \otimes \mathcal{H}_3$$

$$\phi_{\text{out}} = f_3 \circ f_4 \circ f_2^\dagger \circ f_3^\dagger \circ f_1 \circ f_2(\phi_{\text{in}})$$



Follow the line!

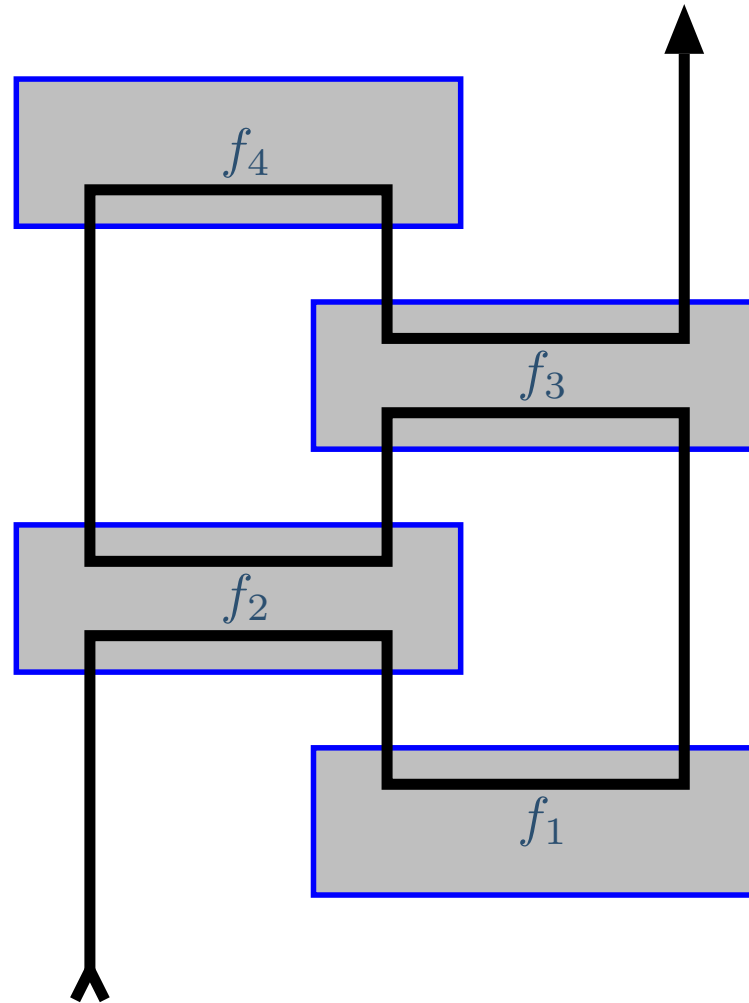

$$f_3 \circ f_4 \circ f_2^\dagger \circ f_3^\dagger \circ f_1 \circ f_2$$



Teleportation: basic case

◊ Title

◊ Overview

Introduction to Quantum
Mechanics

Entanglement

◊ Quantum Entanglement

◊ From 'paradox' to 'feature':
Teleportation

◊ Symmetric leadership
election

◊ Entanglement: where does
the magic come from?

◊ Entangled states as linear
maps

◊ Some notation for
projectors

◊ On the trail of structure

◊ What is the output?

◊ Follow the line!

◊ Teleportation: basic case

◊ Teleportation: general case

◊ Logic-Gate Teleportation

◊ Entanglement Swapping

◊ The Logic of Lines

◊ Sets and Relations have
the same structure!

Categorical Quantum
Mechanics

The Graphical Calculus

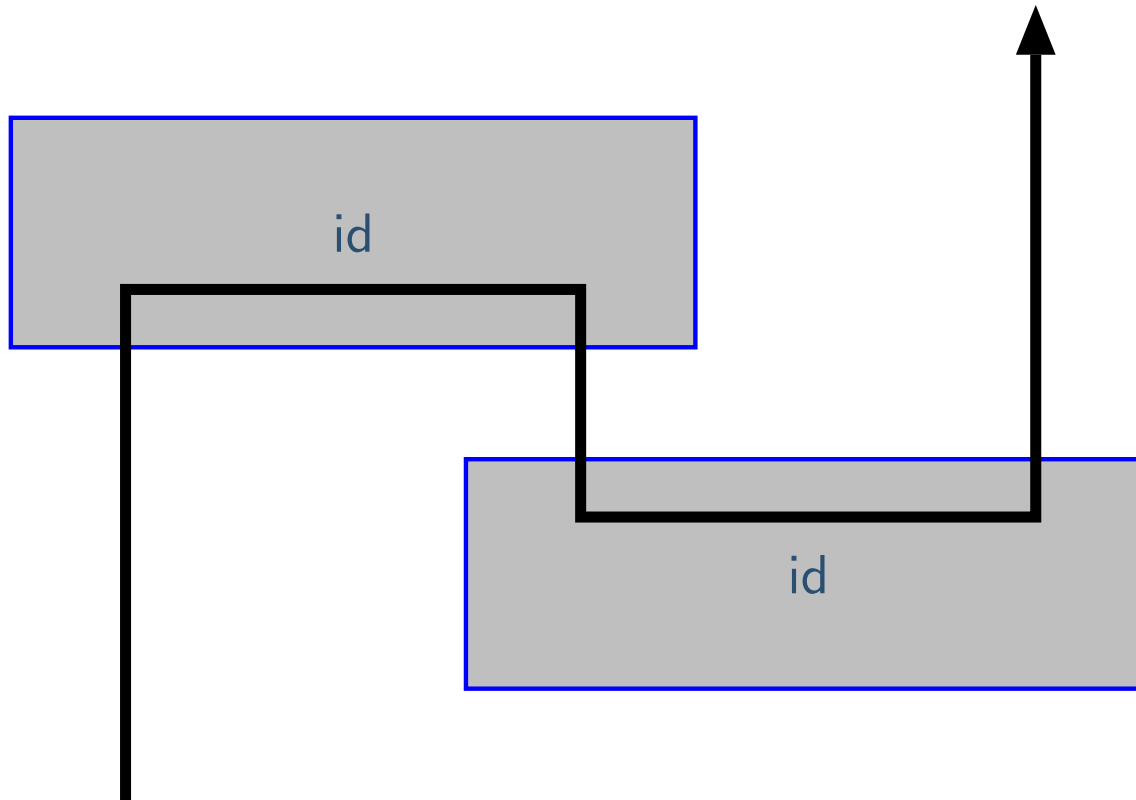

$$\text{id} \circ \text{id} = \text{id}$$



Logic-Gate Teleportation

- ▷ Title
- ▷ Overview

Introduction to Quantum Mechanics

Entanglement

- ▷ Quantum Entanglement
- ▷ From 'paradox' to 'feature': Teleportation
- ▷ Symmetric leadership election
- ▷ Entanglement: where does the magic come from?
- ▷ Entangled states as linear maps
- ▷ Some notation for projectors
- ▷ On the trail of structure
- ▷ What is the output?
- ▷ Follow the line!
- ▷ Teleportation: basic case
- ▷ Teleportation: general case
- ▷ Logic-Gate Teleportation
- ▷ Entanglement Swapping
- ▷ The Logic of Lines
- ▷ Sets and Relations have the same structure!

Categorical Quantum Mechanics

The Graphical Calculus

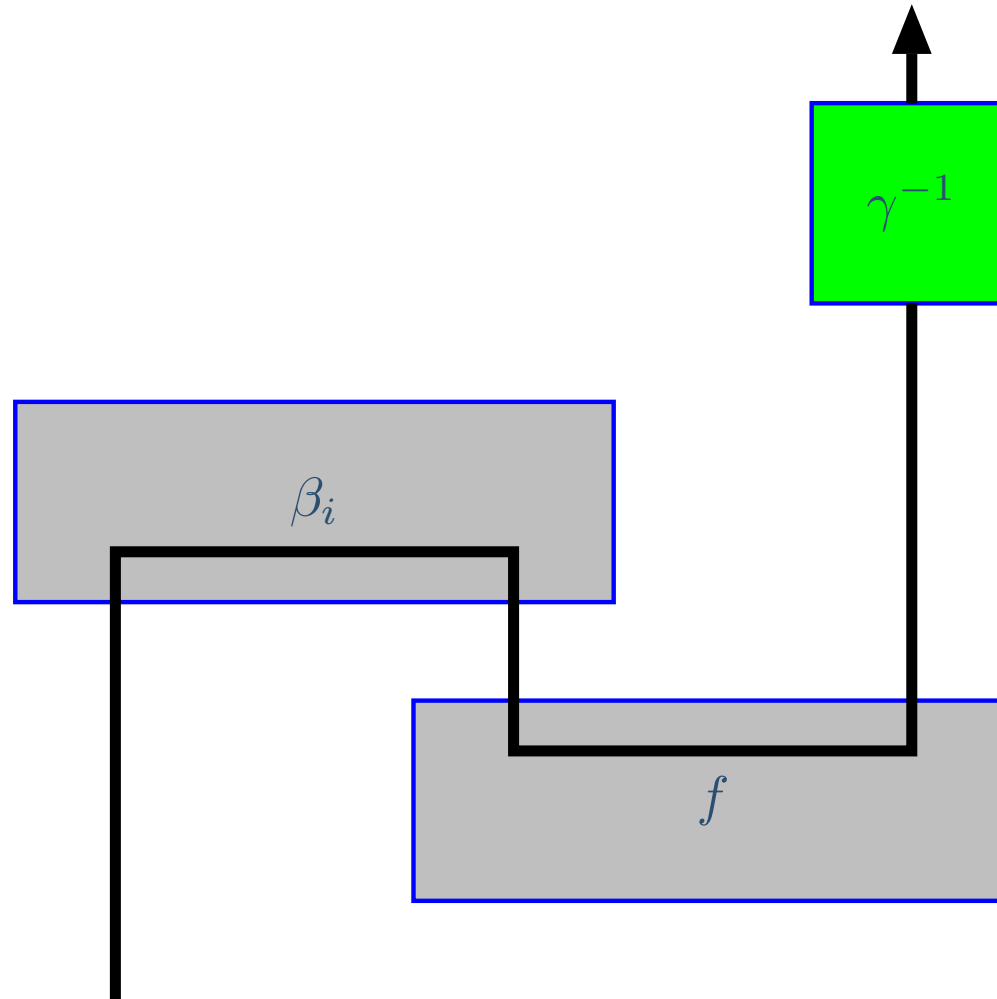

$$\gamma_i^{-1} \circ f \circ \beta_i = f, \quad 1 \leq i \leq 4$$



Entanglement Swapping

◻ Title

◻ Overview

Introduction to Quantum Mechanics

Entanglement

◻ Quantum Entanglement

◻ From 'paradox' to 'feature':

Teleportation

◻ Symmetric leadership

election

◻ Entanglement: where does the magic come from?

◻ Entangled states as linear maps

◻ Some notation for projectors

◻ On the trail of structure

◻ What is the output?

◻ Follow the line!

◻ Teleportation: basic case

◻ Teleportation: general case

◻ Logic-Gate Teleportation

◻ Entanglement Swapping

◻ The Logic of Lines

◻ Sets and Relations have the same structure!

Categorical Quantum Mechanics

The Graphical Calculus

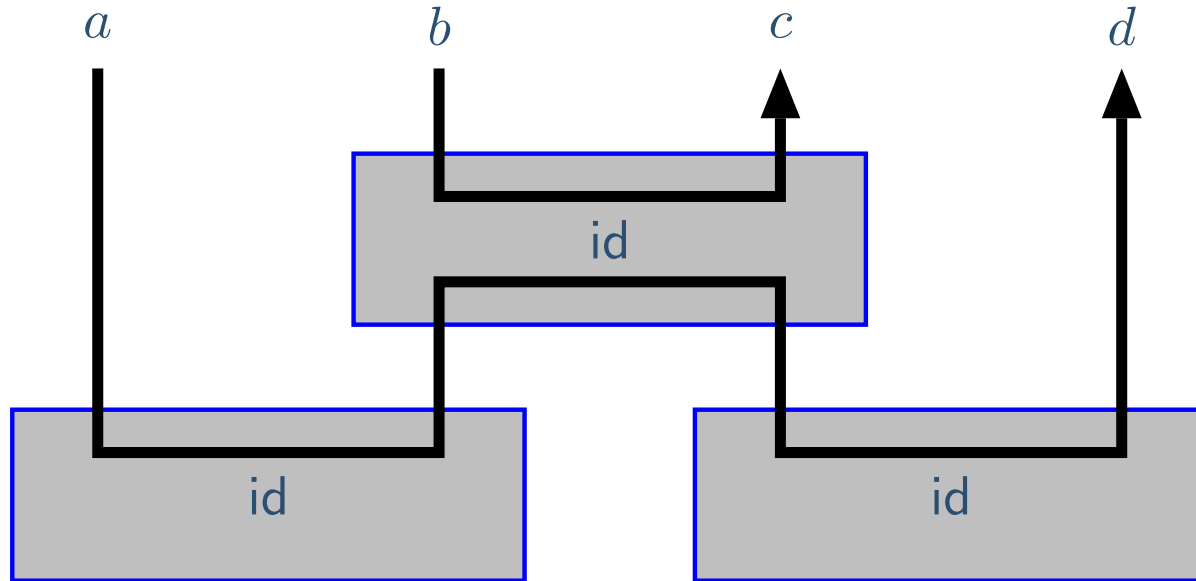

$$\text{id} \circ \text{id} \circ \text{id} = \text{id}$$



The Logic of Lines

Permitted:

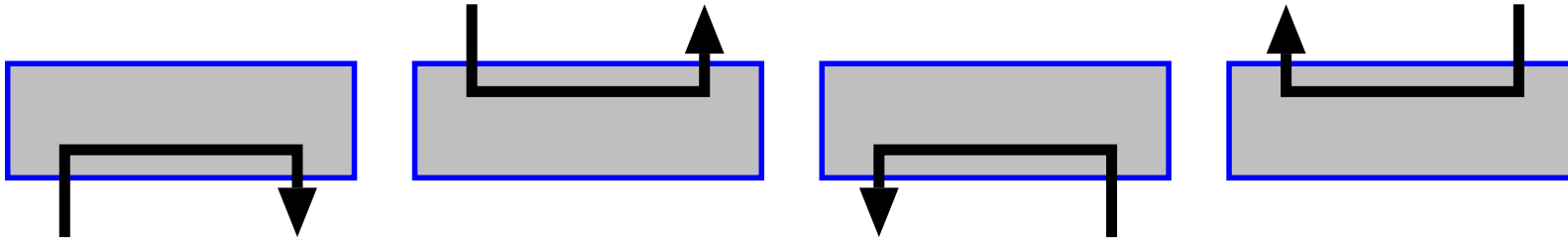

Forbidden:

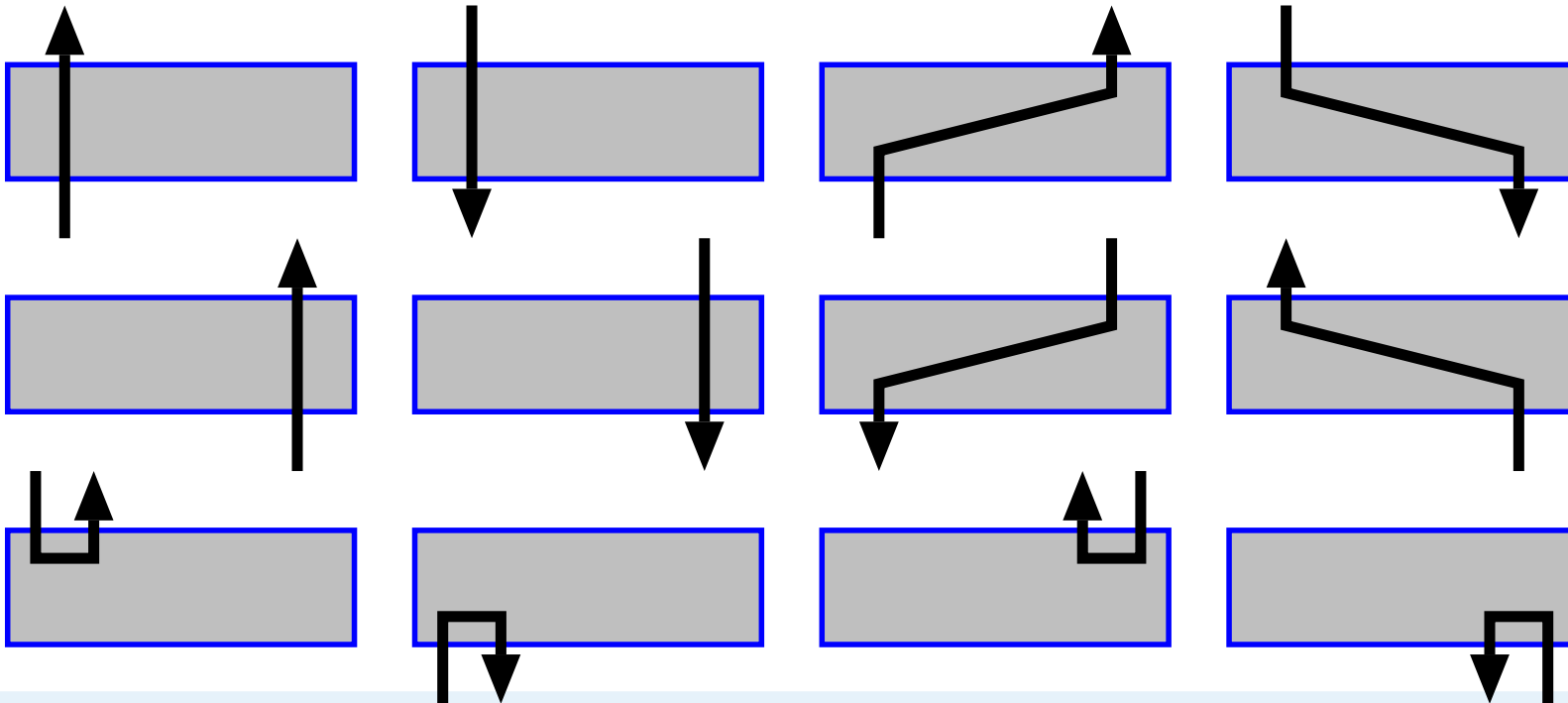



Sets and Relations have the same structure!

Hilbert space \rightsquigarrow **set**
 linear map \rightsquigarrow **relation**
 tensor product \rightsquigarrow **cartesian product**

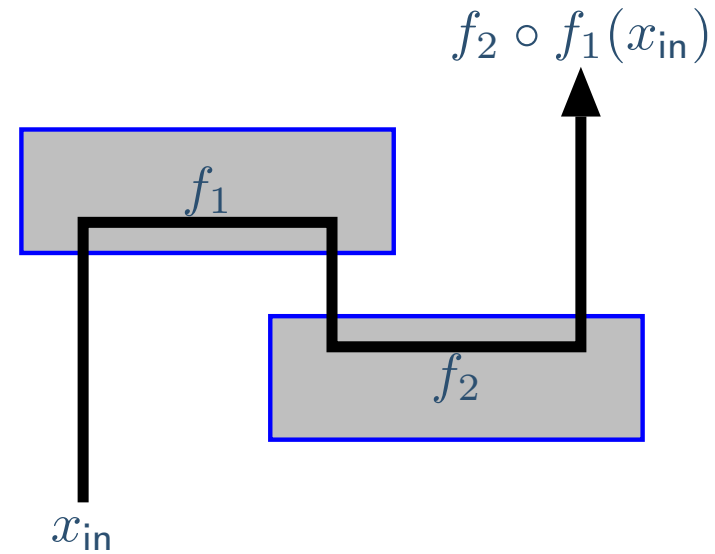

$$(\mathbf{P}_{f_1} \otimes 1) \circ (1 \otimes \mathbf{P}_{f_2})(x_{in} \otimes \dots) = \dots \otimes (f_2 \circ f_1)(x_{in})$$

Here the corresponding notion of 'projector' is

$$\mathbf{P}_R = R \times R = \{((x_1, y_1), (x_2, y_2)) \mid x_1 R y_1 \wedge x_2 R y_2\}$$



Axiomatization: Strong Compact Closure

- ◻ Title
- ◻ Overview

Introduction to Quantum Mechanics

Entanglement

Categorical Quantum Mechanics

- ◻ Axiomatization: Strong Compact Closure
- ◻ Mathematical Foundations of Quantum Mechanics
- ◻ Teleportation categorically

The Graphical Calculus

Conclusions

It suffices to require the following structure on a symmetric monoidal category $(\mathcal{C}, \otimes, I, \sigma)$:

- ▲ A monoidal involutive assignment $()^*$ on objects.
- ▲ An identity on objects, contravariant, involutive, strictly monoidal functor $()^\dagger$ (so we take the adjoint as primitive).
- ▲ An assignment of units $\eta_A : I \rightarrow A^* \otimes A$ such that

$$\eta_{A^*} = \sigma_{A^*, A} \circ \eta_A.$$

We can then *define* $\epsilon_A = \eta_A^\dagger \circ \sigma_{A, A^*}$.

Triangular identities:

$$A \xrightarrow{1_A \otimes \eta_A} A \otimes A^* \otimes A \xrightarrow{\epsilon_A \otimes 1_A} A = 1_A$$

$$A^* \xrightarrow{\eta_A \otimes 1_A} A^* \otimes A \otimes A^* \xrightarrow{1_A \otimes \epsilon_A} A^* = 1_{A^*}$$



Mathematical Foundations of Quantum Mechanics

▣ Title

▣ Overview

Introduction to Quantum
Mechanics

Entanglement

Categorical Quantum
Mechanics

▣ Axiomatization: Strong

Compact Closure

▣ Mathematical Foundations
of Quantum Mechanics

▣ Teleportation categorically

The Graphical Calculus

Conclusions



Mathematical Foundations of Quantum Mechanics

Old Picture (von Neumann 1932) State space is Hilbert space. Operations are operators on this space — unitaries for ‘undisturbed dynamics’, self-adjoint operators for measurements. There is only one type!

◻ Title

◻ Overview

Introduction to Quantum
Mechanics

Entanglement

Categorical Quantum
Mechanics

◻ Axiomatization: Strong

Compact Closure

◻ Mathematical Foundations
of Quantum Mechanics

◻ Teleportation categorically

The Graphical Calculus

Conclusions



Mathematical Foundations of Quantum Mechanics

- ◻ Title
- ◻ Overview

Introduction to Quantum Mechanics

Entanglement

Categorical Quantum Mechanics

- ◻ Axiomatization: Strong Compact Closure
- ◻ Mathematical Foundations of Quantum Mechanics
- ◻ Teleportation categorically

The Graphical Calculus

Conclusions

Old Picture (von Neumann 1932) State space is Hilbert space. Operations are operators on this space — unitaries for ‘undisturbed dynamics’, self-adjoint operators for measurements. There is only one type!

New Picture QM can be done in *any strongly compact closed category with biproducts*. Compound systems represented by *abstract tensor* $A \otimes B$. Branching on measurement outcomes can now be represented explicitly using *abstract direct sum* $A \oplus B$:

$$A \xrightarrow{M} \bigoplus_{i=1}^n A_i \xrightarrow{\bigoplus_{i=1}^n U_i} \bigoplus_{i=1}^n B_i$$

Propagation of the outcome of a measurement performed on one part of a compound system to other parts — “classical communication” — can be expressed using *distributivity*:

$$(A_1 \oplus A_2) \otimes B \cong (A_1 \otimes B) \oplus (A_2 \otimes B).$$



Teleportation categorically

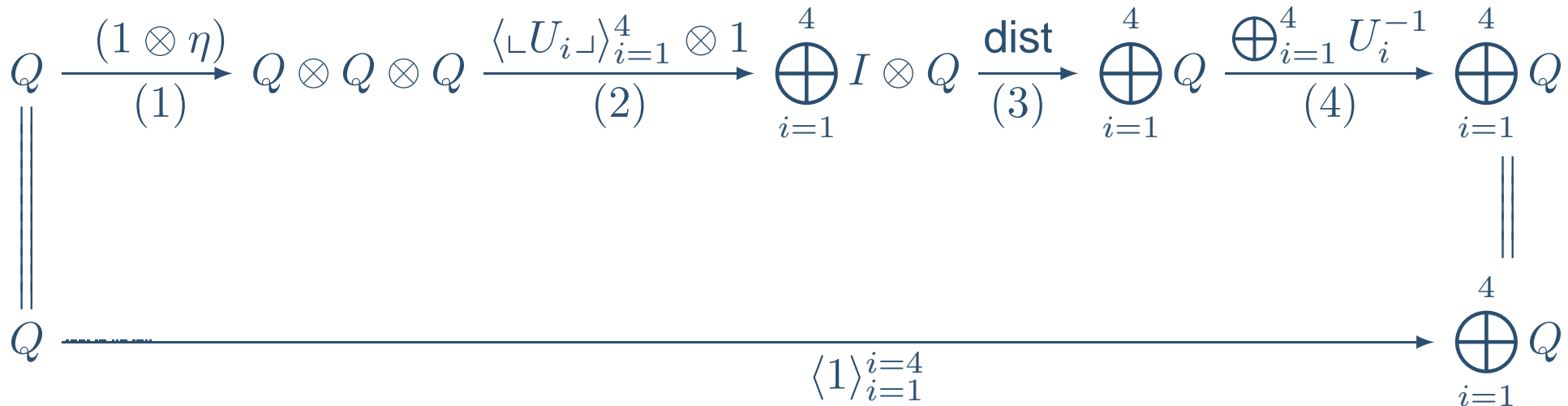

- (1) **Produce EPR pair**
- (2) **Perform measurement in Bell-basis**
- (3) **Propagate classical information**
- (4) **Perform unitary correction.**



Boxes and Wires: Typed Operations

- ▣ Title
- ▣ Overview
- Introduction to Quantum Mechanics
- Entanglement
- Categorical Quantum Mechanics
- The Graphical Calculus
 - ▣ Boxes and Wires: Typed Operations
 - ▣ Series and Parallel Composition
 - ▣ Geometry absorbs Functoriality, Naturality
 - ▣ Bras, Kets and Scalars
 - ▣ Dual Arrows — 180° rotation
 - ▣ Adjoint Arrows — reflection in the x -axis
 - ▣ Cups and Caps
 - ▣ Graphical Calculus for Information Flow
 - ▣ Names and Conames in the Graphical Calculus
 - ▣ Bipartite Projectors
 - ▣ Projectors Decomposed
 - ▣ Compositionality
 - ▣ Compositionality ctd
 - ▣ Compositionality ctd
 - ▣ Teleportation

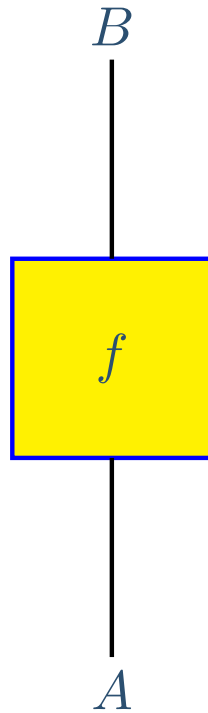

$$f : A \longrightarrow B$$

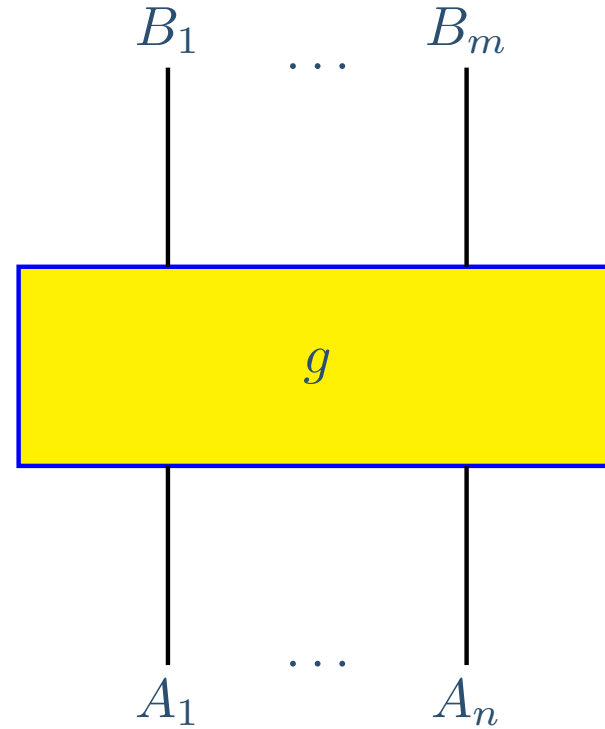

$$g : A_1 \otimes \cdots \otimes A_n \longrightarrow B_1 \otimes \cdots \otimes B_m.$$



Series and Parallel Composition

- ◻ Title
- ◻ Overview
- Introduction to Quantum Mechanics

- Entanglement

- Categorical Quantum Mechanics

- The Graphical Calculus
- ◻ Boxes and Wires: Typed Operations
- ◻ Series and Parallel Composition
- ◻ Geometry absorbs Functoriality, Naturality
- ◻ Bras, Kets and Scalars
- ◻ Dual Arrows — 180° rotation
- ◻ Adjoint Arrows — reflection in the x -axis
- ◻ Cups and Caps
- ◻ Graphical Calculus for Information Flow
- ◻ Names and Conames in the Graphical Calculus
- ◻ Bipartite Projectors
- ◻ Projectors Decomposed
- ◻ Compositionality
- ◻ Compositionality ctd
- ◻ Compositionality ctd
- ◻ Teleportation

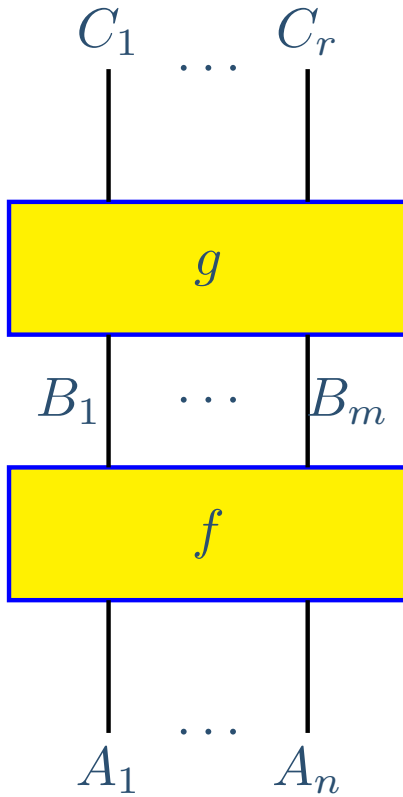

$$g \circ f$$

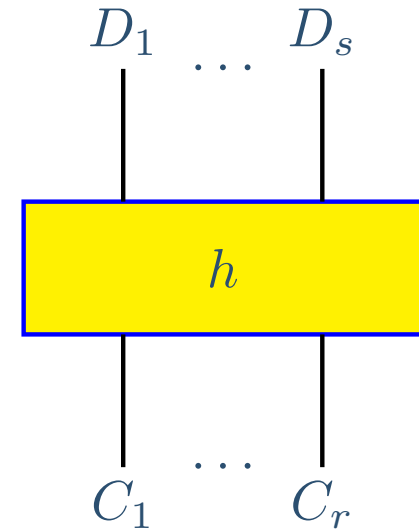
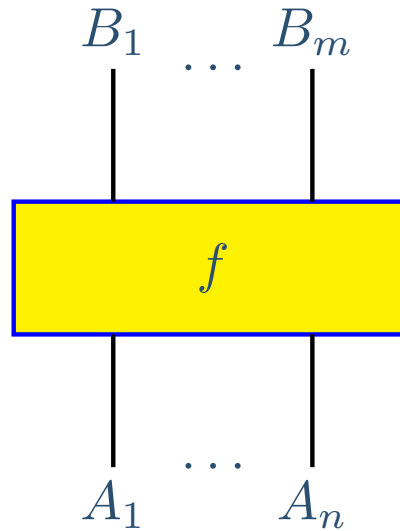

$$f \otimes h$$



Geometry absorbs Functoriality, Naturality

- ◊ Title
- ◊ Overview
- Introduction to Quantum Mechanics
- Entanglement
- Categorical Quantum Mechanics
- The Graphical Calculus
 - ◊ Boxes and Wires: Typed Operations
 - ◊ Series and Parallel Composition
 - ◊ Geometry absorbs Functoriality, Naturality
 - ◊ Bras, Kets and Scalars
 - ◊ Dual Arrows — 180° rotation
 - ◊ Adjoint Arrows — reflection in the x -axis
 - ◊ Cups and Caps
 - ◊ Graphical Calculus for Information Flow
 - ◊ Names and Conames in the Graphical Calculus
 - ◊ Bipartite Projectors
 - ◊ Projectors Decomposed
 - ◊ Compositionality
 - ◊ Compositionality ctd
 - ◊ Compositionality ctd
 - ◊ Teleportation

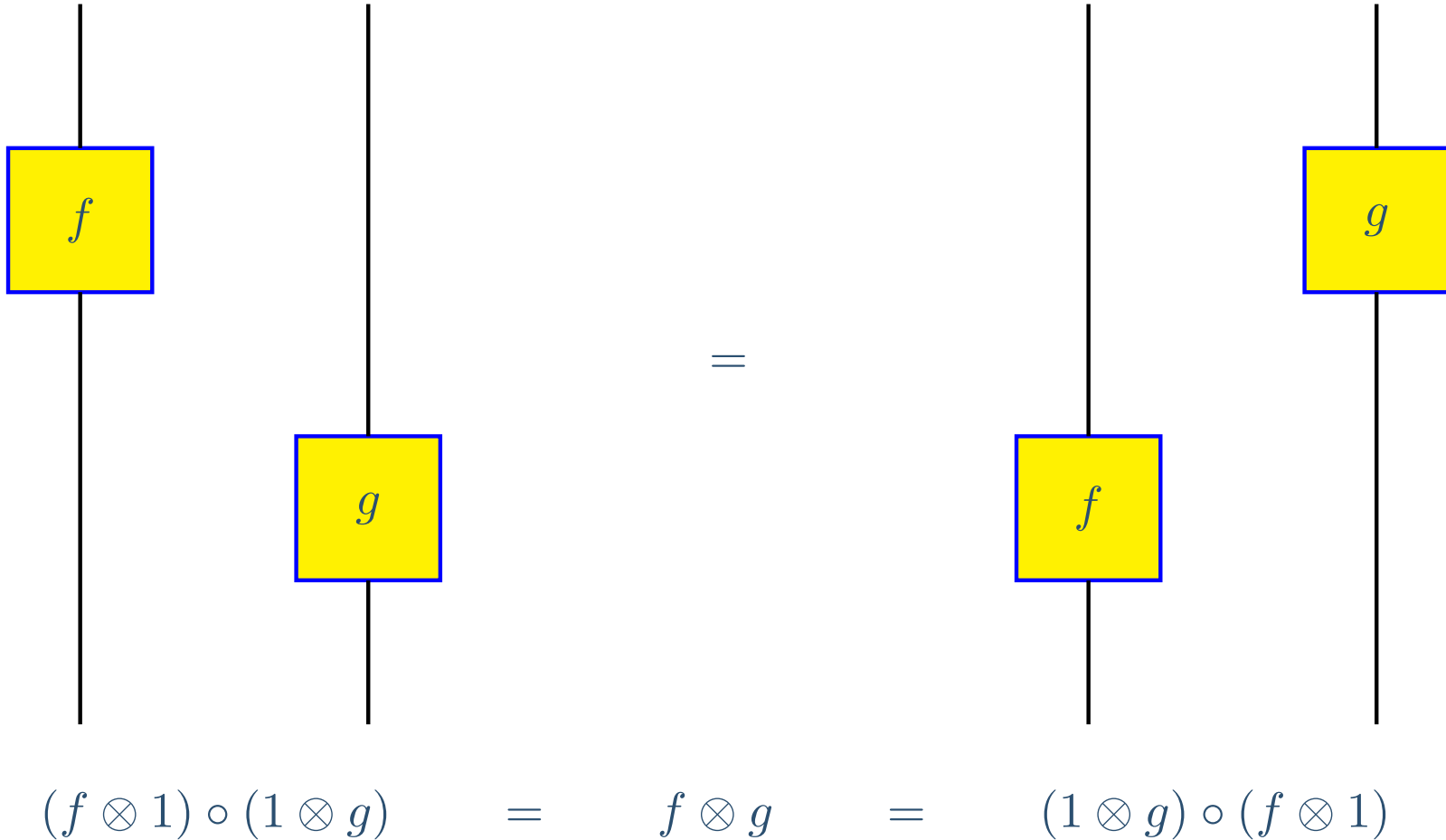



Bras, Kets and Scalars

- ▣ Title
- ▣ Overview

Introduction to Quantum Mechanics

Entanglement

Categorical Quantum Mechanics

The Graphical Calculus

- ▣ Boxes and Wires: Typed Operations
- ▣ Series and Parallel Composition
- ▣ Geometry absorbs Functoriality, Naturality
- ▣ Bras, Kets and Scalars
- ▣ Dual Arrows — 180° rotation
- ▣ Adjoint Arrows — reflection in the x -axis
- ▣ Cups and Caps
- ▣ Graphical Calculus for Information Flow
- ▣ Names and Conames in the Graphical Calculus
- ▣ Bipartite Projectors
- ▣ Projectors Decomposed
- ▣ Compositionality
- ▣ Compositionality ctd
- ▣ Compositionality ctd
- ▣ Teleportation

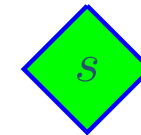
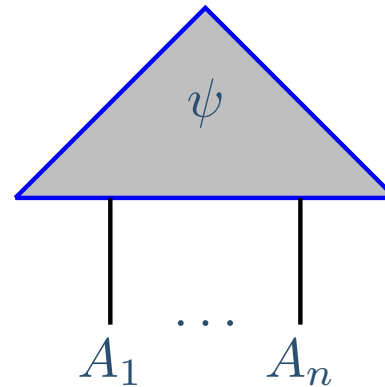
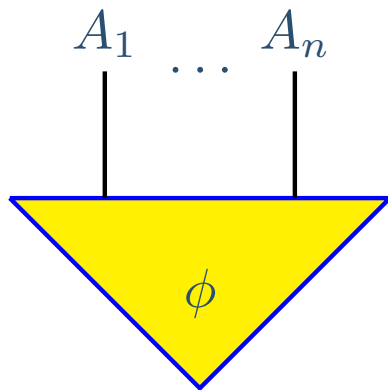

$$\phi : A_1 \otimes \cdots \otimes A_n \longrightarrow I$$

$$\psi : I \longrightarrow A_1 \otimes \cdots \otimes A_n$$

$$s : I \longrightarrow I.$$

Bras: no outputs

Kets: no inputs

Scalars: no inputs or outputs.



Dual Arrows — 180° rotation

- Title
- Overview
- Introduction to Quantum Mechanics
- Entanglement
- Categorical Quantum Mechanics
- The Graphical Calculus
 - Boxes and Wires: Typed Operations
 - Series and Parallel Composition
 - Geometry absorbs Functoriality, Naturality
 - Bras, Kets and Scalars
 - Dual Arrows — 180° rotation
 - Adjoint Arrows — reflection in the x -axis
 - Cups and Caps
 - Graphical Calculus for Information Flow
 - Names and Conames in the Graphical Calculus
 - Bipartite Projectors
 - Projectors Decomposed
 - Compositionality
 - Compositionality ctd
 - Compositionality ctd
 - Teleportation

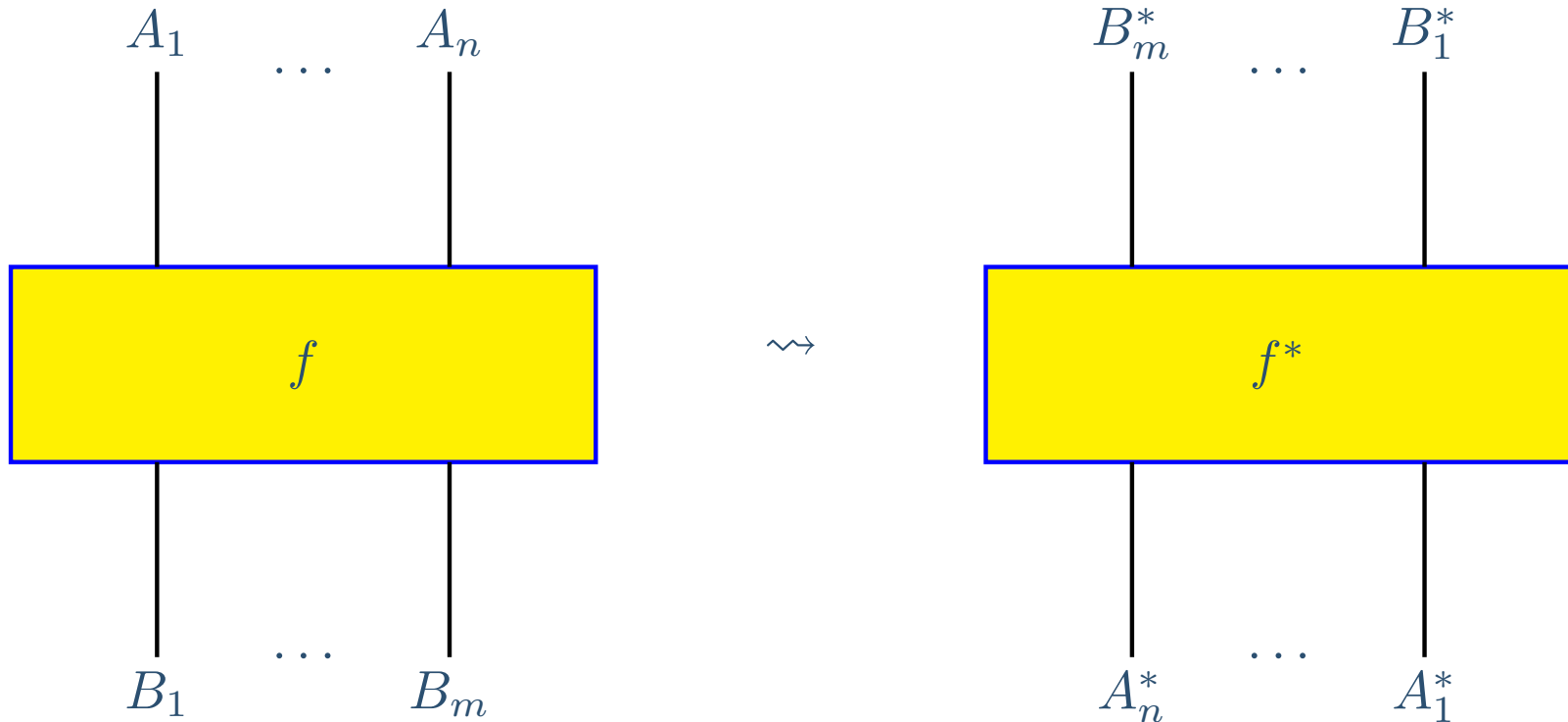



Adjoint Arrows — reflection in the x -axis

- Title
- Overview
- Introduction to Quantum Mechanics
- Entanglement
- Categorical Quantum Mechanics
- The Graphical Calculus
 - Boxes and Wires: Typed Operations
 - Series and Parallel Composition
 - Geometry absorbs Functoriality, Naturality
 - Bras, Kets and Scalars
 - Dual Arrows — 180° rotation
 - Adjoint Arrows — reflection in the x -axis
 - Cups and Caps
 - Graphical Calculus for Information Flow
 - Names and Conames in the Graphical Calculus
 - Bipartite Projectors
 - Projectors Decomposed
 - Compositionality
 - Compositionality ctd
 - Compositionality ctd
 - Teleportation

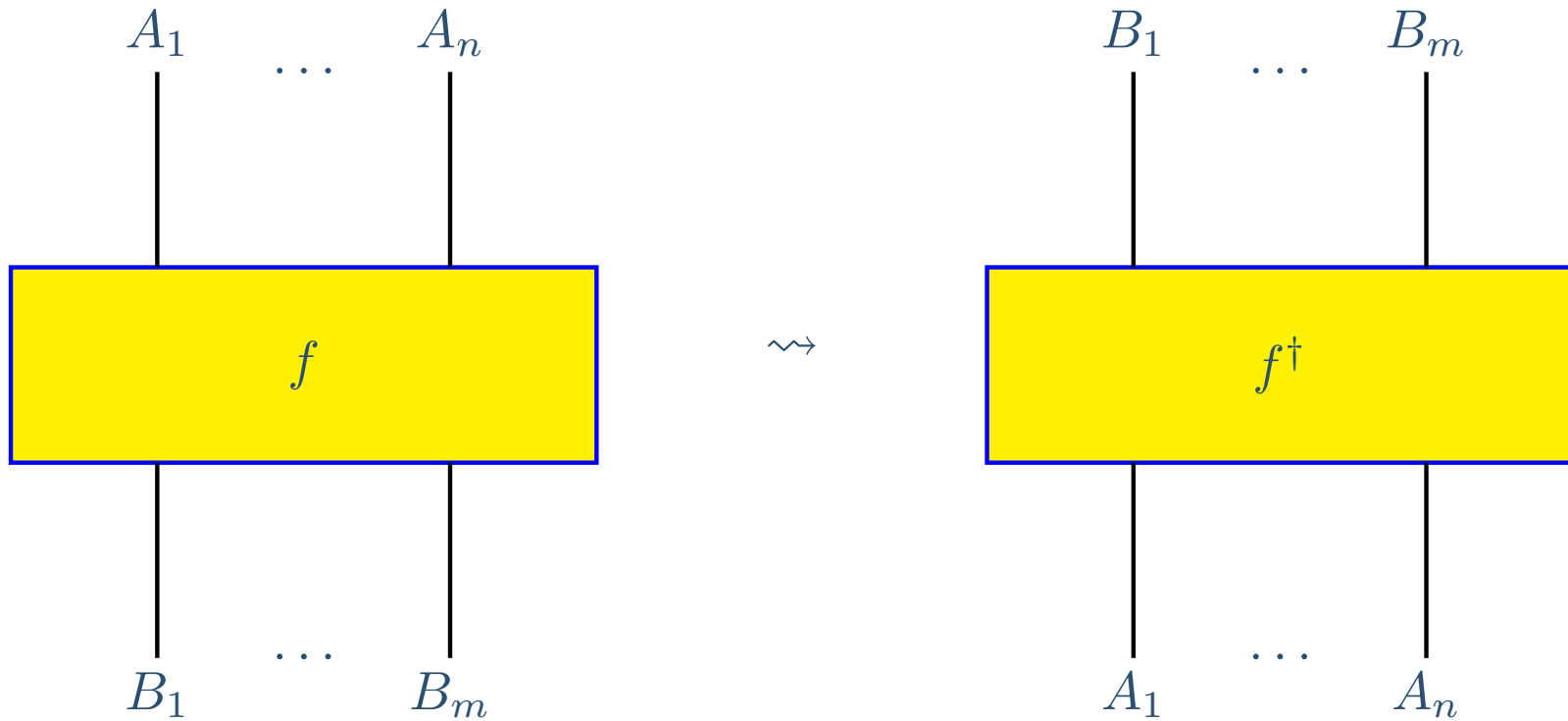



Cups and Caps

- ◻ Title
- ◻ Overview

Introduction to Quantum Mechanics

Entanglement

Categorical Quantum Mechanics

The Graphical Calculus

- ◻ Boxes and Wires: Typed Operations
- ◻ Series and Parallel Composition
- ◻ Geometry absorbs Functoriality, Naturality
- ◻ Bras, Kets and Scalars
- ◻ Dual Arrows — 180° rotation
- ◻ Adjoint Arrows — reflection in the x -axis
- ◻ Cups and Caps
- ◻ Graphical Calculus for Information Flow
- ◻ Names and Conames in the Graphical Calculus
- ◻ Bipartite Projectors
- ◻ Projectors Decomposed
- ◻ Compositionality
- ◻ Compositionality ctd
- ◻ Compositionality ctd
- ◻ Teleportation

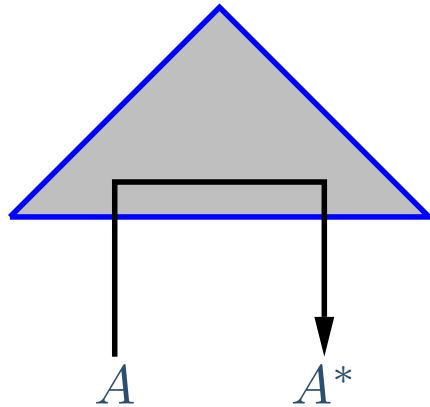

$$\epsilon_A : A \otimes A^* \longrightarrow I$$

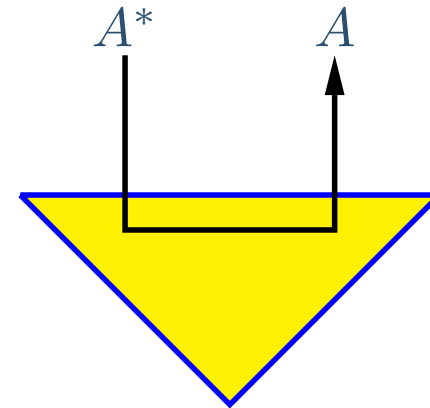

$$\eta_A : I \longrightarrow A^* \otimes A.$$

Caps = Bell States; Cups = Bell Tests.



Graphical Calculus for Information Flow

Compact Closure: The basic algebraic laws for units and counits.

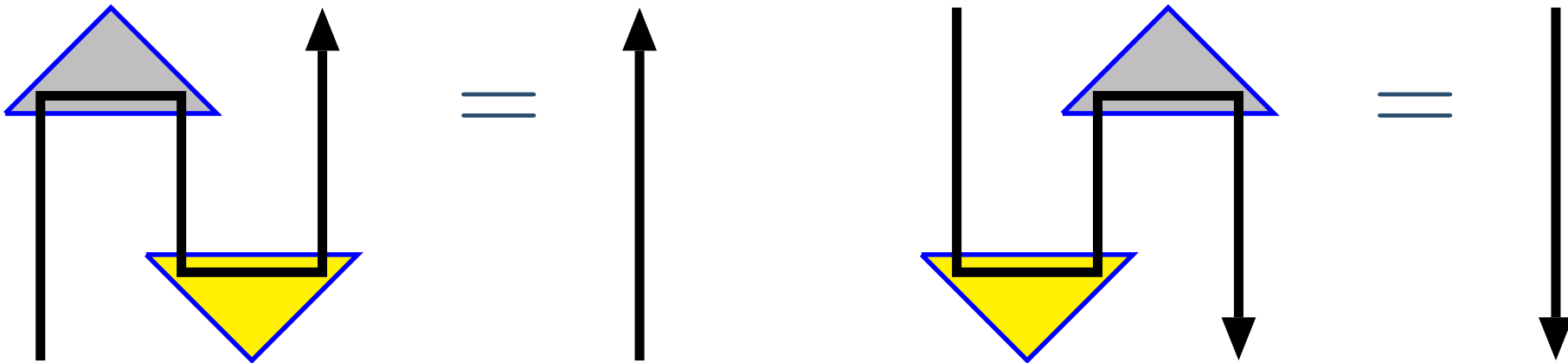

$$(\epsilon_A \otimes 1_A) \circ (1_A \otimes \eta_A) = 1_A$$

$$(1_{A^*} \otimes \epsilon_A) \circ (\eta_A \otimes 1_{A^*}) = 1_{A^*}$$



Names and Conames in the Graphical Calculus

▣ Title

▣ Overview

Introduction to Quantum
Mechanics

Entanglement

Categorical Quantum
Mechanics

The Graphical Calculus

▣ Boxes and Wires: Typed
Operations

▣ Series and Parallel
Composition

▣ Geometry absorbs
Functoriality, Naturality

▣ Bras, Kets and Scalars

▣ Dual Arrows — 180°
rotation

▣ Adjoint Arrows — reflection
in the x -axis

▣ Cups and Caps

▣ Graphical Calculus for
Information Flow

▣ Names and Conames in
the Graphical Calculus

▣ Bipartite Projectors

▣ Projectors Decomposed

▣ Compositionality

▣ Compositionality ctd

▣ Compositionality ctd

▣ Teleportation

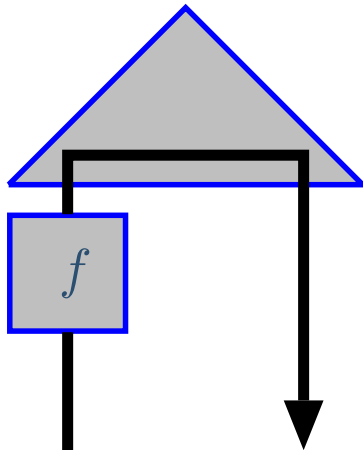

$$\lfloor f \rfloor : A \otimes B^* \rightarrow I$$

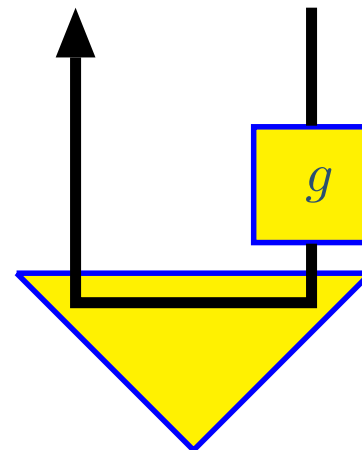

$$\lceil f \rceil : I \rightarrow A^* \otimes B$$

$$\mathcal{C}(A \otimes B^*, I) \simeq \mathcal{C}(A, B) \simeq \mathcal{C}(I, A^* \otimes B).$$



Bipartite Projectors

Information flow in entangled states can be captured mathematically by the isomorphism

$$\mathbf{Hom}(A, B) \cong A^* \otimes B.$$

This leads to a *decomposition* of bipartite projectors into “names” (preparations) and “conames” (measurements).

In graphical notation:

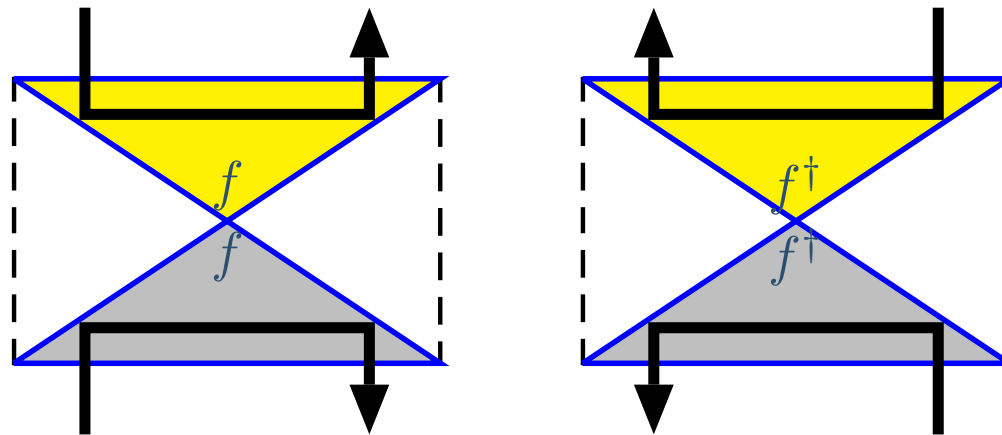

- ◻ Title
- ◻ Overview
- Introduction to Quantum Mechanics
- Entanglement
- Categorical Quantum Mechanics
- The Graphical Calculus
 - ◻ Boxes and Wires: Typed Operations
 - ◻ Series and Parallel Composition
 - ◻ Geometry absorbs Functoriality, Naturality
 - ◻ Bras, Kets and Scalars
 - ◻ Dual Arrows — 180° rotation
 - ◻ Adjoint Arrows — reflection in the x -axis
 - ◻ Cups and Caps
 - ◻ Graphical Calculus for Information Flow
 - ◻ Names and Conames in the Graphical Calculus
 - ◻ Bipartite Projectors
 - ◻ Projectors Decomposed
 - ◻ Compositionality
 - ◻ Compositionality ctd
 - ◻ Compositionality ctd
 - ◻ Teleportation



Projectors Decomposed

- ◻ Title
- ◻ Overview
- Introduction to Quantum Mechanics
- Entanglement
- Categorical Quantum Mechanics
- The Graphical Calculus
 - ◻ Boxes and Wires: Typed Operations
 - ◻ Series and Parallel Composition
 - ◻ Geometry absorbs Functoriality, Naturality
 - ◻ Bras, Kets and Scalars
 - ◻ Dual Arrows — 180° rotation
 - ◻ Adjoint Arrows — reflection in the x -axis
 - ◻ Cups and Caps
 - ◻ Graphical Calculus for Information Flow
 - ◻ Names and Conames in the Graphical Calculus
 - ◻ Bipartite Projectors
 - ◻ Projectors Decomposed
 - ◻ Compositionality
 - ◻ Compositionality ctd
 - ◻ Compositionality ctd
 - ◻ Teleportation

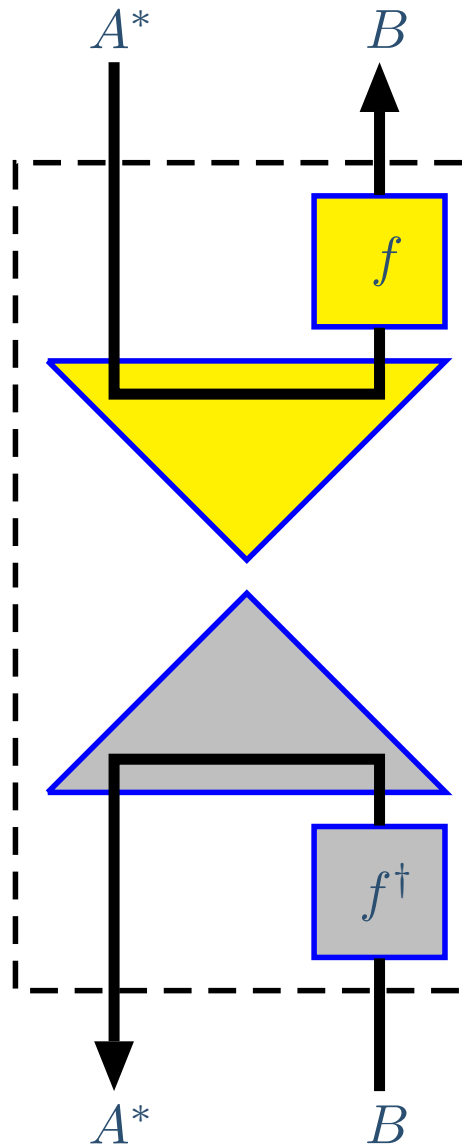



Compositionality

The key algebraic fact from which teleportation (and many other protocols) can be derived.

◦ Title

◦ Overview

Introduction to Quantum Mechanics

Entanglement

Categorical Quantum Mechanics

The Graphical Calculus

◦ Boxes and Wires: Typed Operations

◦ Series and Parallel Composition

◦ Geometry absorbs Functoriality, Naturality

◦ Bras, Kets and Scalars

◦ Dual Arrows — 180° rotation

◦ Adjoint Arrows — reflection in the x -axis

◦ Cups and Caps

◦ Graphical Calculus for Information Flow

◦ Names and Conames in the Graphical Calculus

◦ Bipartite Projectors

◦ Projectors Decomposed

◦ Compositionality

◦ Compositionality ctd

◦ Compositionality ctd

◦ Teleportation

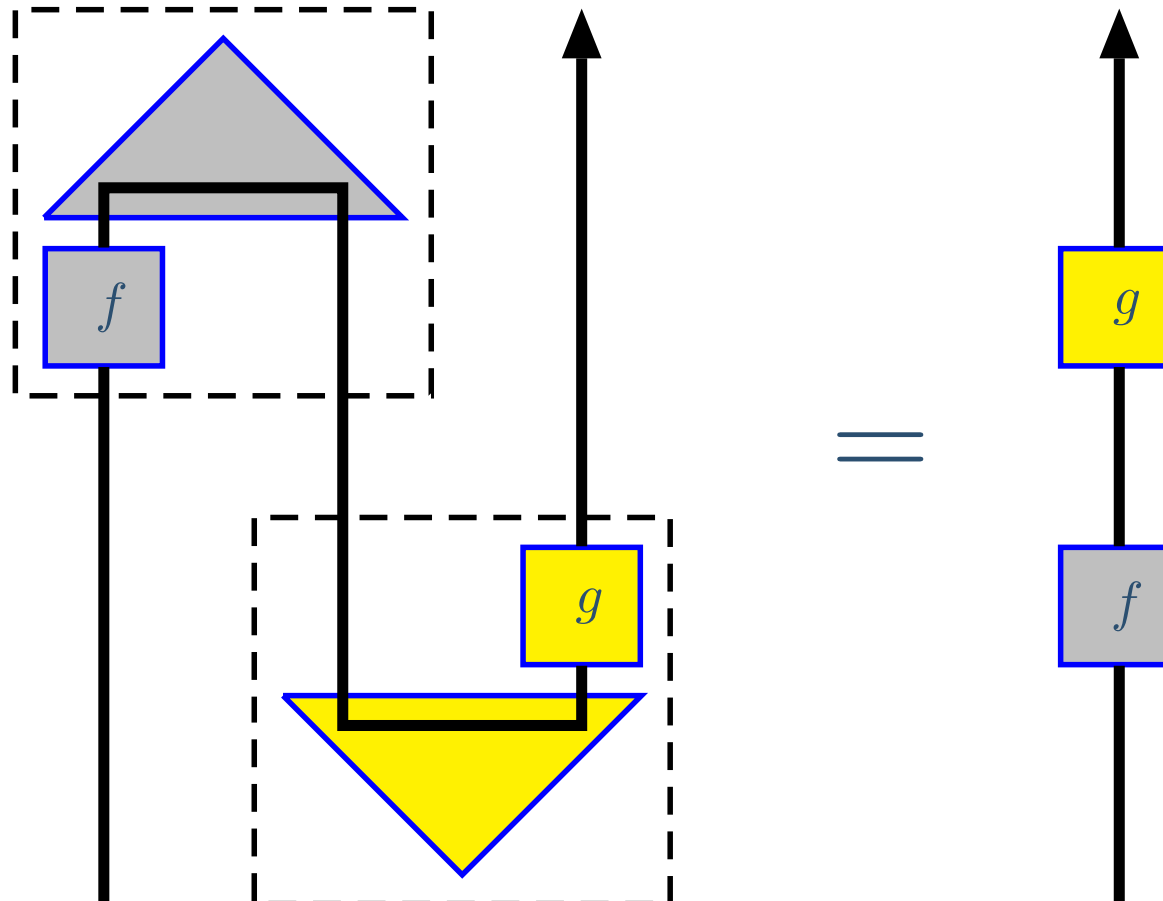



Compositionality ctd

- ◻ Title
- ◻ Overview
- Introduction to Quantum Mechanics
- Entanglement
- Categorical Quantum Mechanics
- The Graphical Calculus
 - ◻ Boxes and Wires: Typed Operations
 - ◻ Series and Parallel Composition
 - ◻ Geometry absorbs Functoriality, Naturality
 - ◻ Bras, Kets and Scalars
 - ◻ Dual Arrows — 180° rotation
 - ◻ Adjoint Arrows — reflection in the x -axis
 - ◻ Cups and Caps
 - ◻ Graphical Calculus for Information Flow
 - ◻ Names and Conames in the Graphical Calculus
 - ◻ Bipartite Projectors
 - ◻ Projectors Decomposed
 - ◻ Compositionality
 - ◻ Compositionality ctd
 - ◻ Compositionality ctd
 - ◻ Teleportation

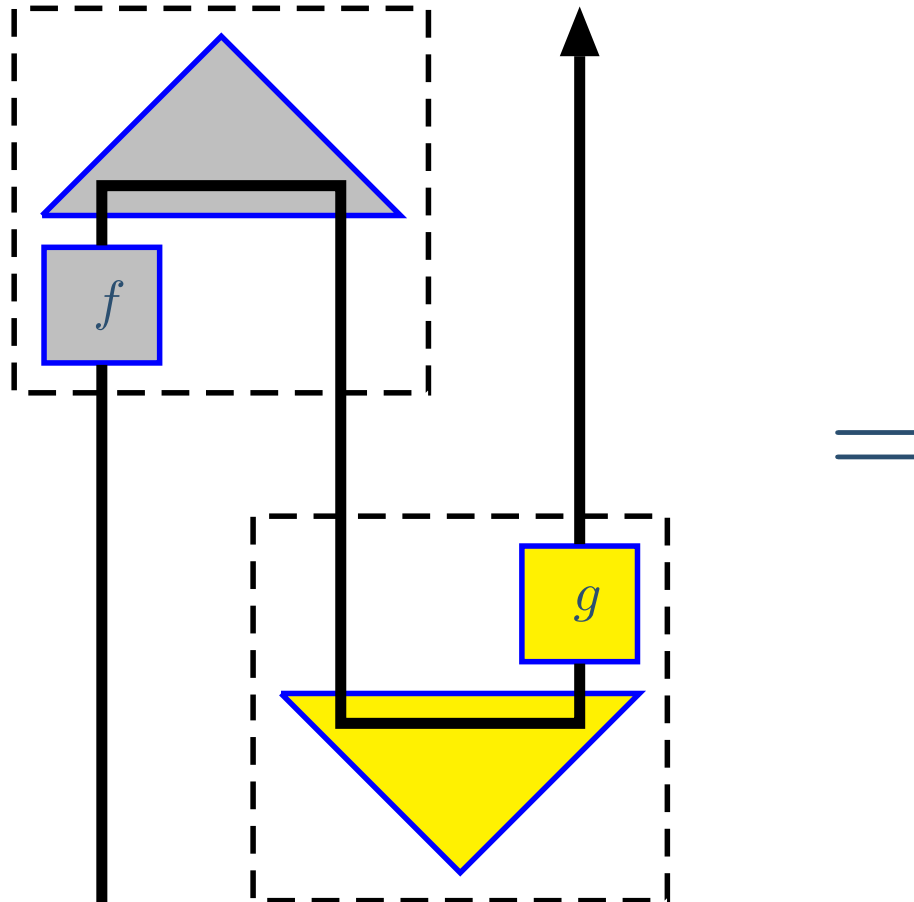



Compositionality ctd

- ◊ Title
- ◊ Overview
- Introduction to Quantum Mechanics
- Entanglement
- Categorical Quantum Mechanics
- The Graphical Calculus
 - ◊ Boxes and Wires: Typed Operations
 - ◊ Series and Parallel Composition
 - ◊ Geometry absorbs Functoriality, Naturality
 - ◊ Bras, Kets and Scalars
 - ◊ Dual Arrows — 180° rotation
 - ◊ Adjoint Arrows — reflection in the x -axis
 - ◊ Cups and Caps
 - ◊ Graphical Calculus for Information Flow
 - ◊ Names and Conames in the Graphical Calculus
 - ◊ Bipartite Projectors
 - ◊ Projectors Decomposed
 - ◊ Compositionality
 - ◊ Compositionality ctd
 - ◊ Compositionality ctd
 - ◊ Teleportation

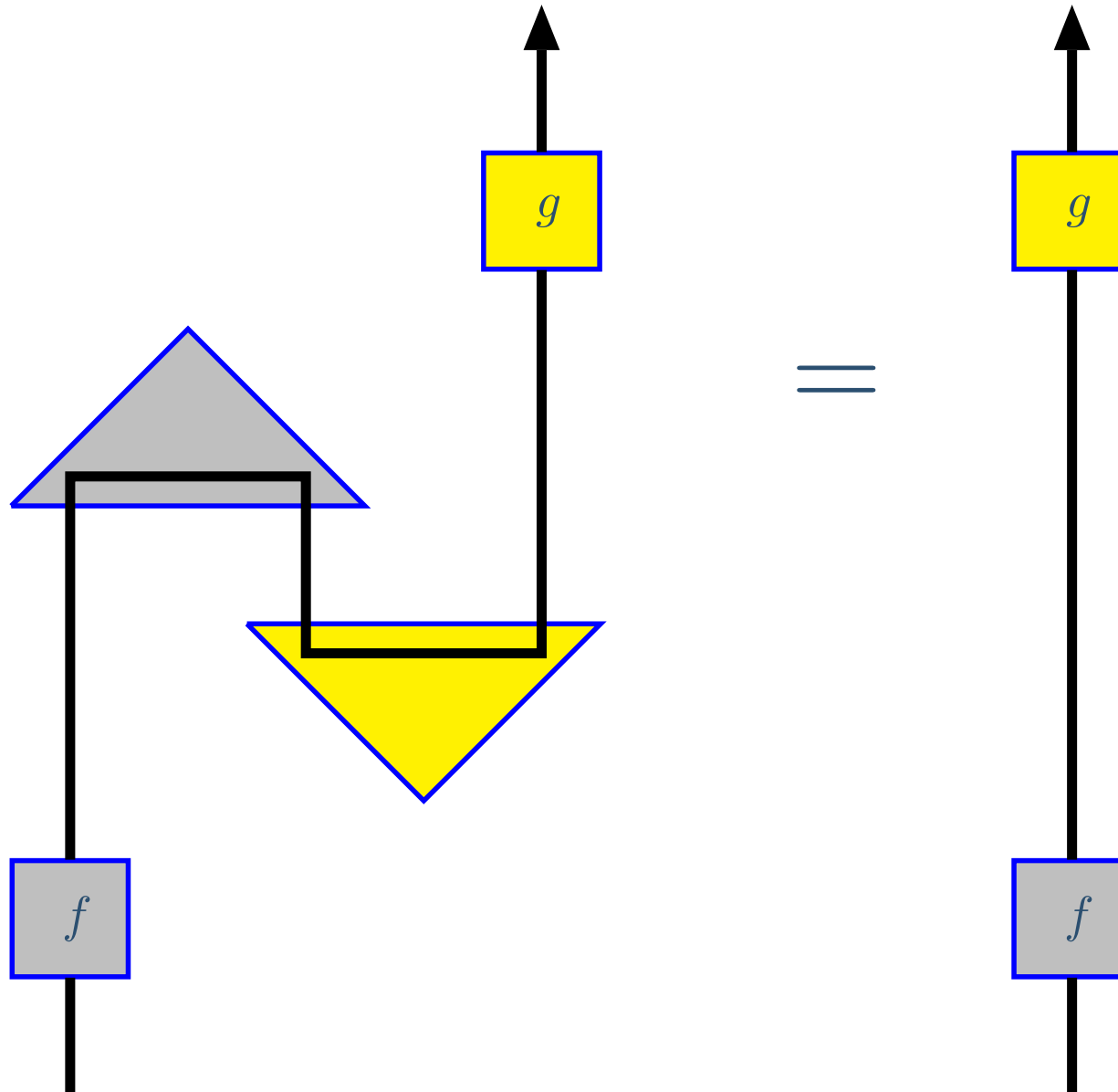



Teleportation diagrammatically

- ◻ Title
- ◻ Overview
- Introduction to Quantum Mechanics
- Entanglement
- Categorical Quantum Mechanics
- The Graphical Calculus
 - ◻ Boxes and Wires: Typed Operations
 - ◻ Series and Parallel Composition
 - ◻ Geometry absorbs Functoriality, Naturality
 - ◻ Bras, Kets and Scalars
 - ◻ Dual Arrows — 180° rotation
 - ◻ Adjoint Arrows — reflection in the x -axis
 - ◻ Cups and Caps
 - ◻ Graphical Calculus for Information Flow
 - ◻ Names and Conames in the Graphical Calculus
 - ◻ Bipartite Projectors
 - ◻ Projectors Decomposed
 - ◻ Compositionality
 - ◻ Compositionality ctd
 - ◻ Compositionality ctd
 - ◻ Teleportation

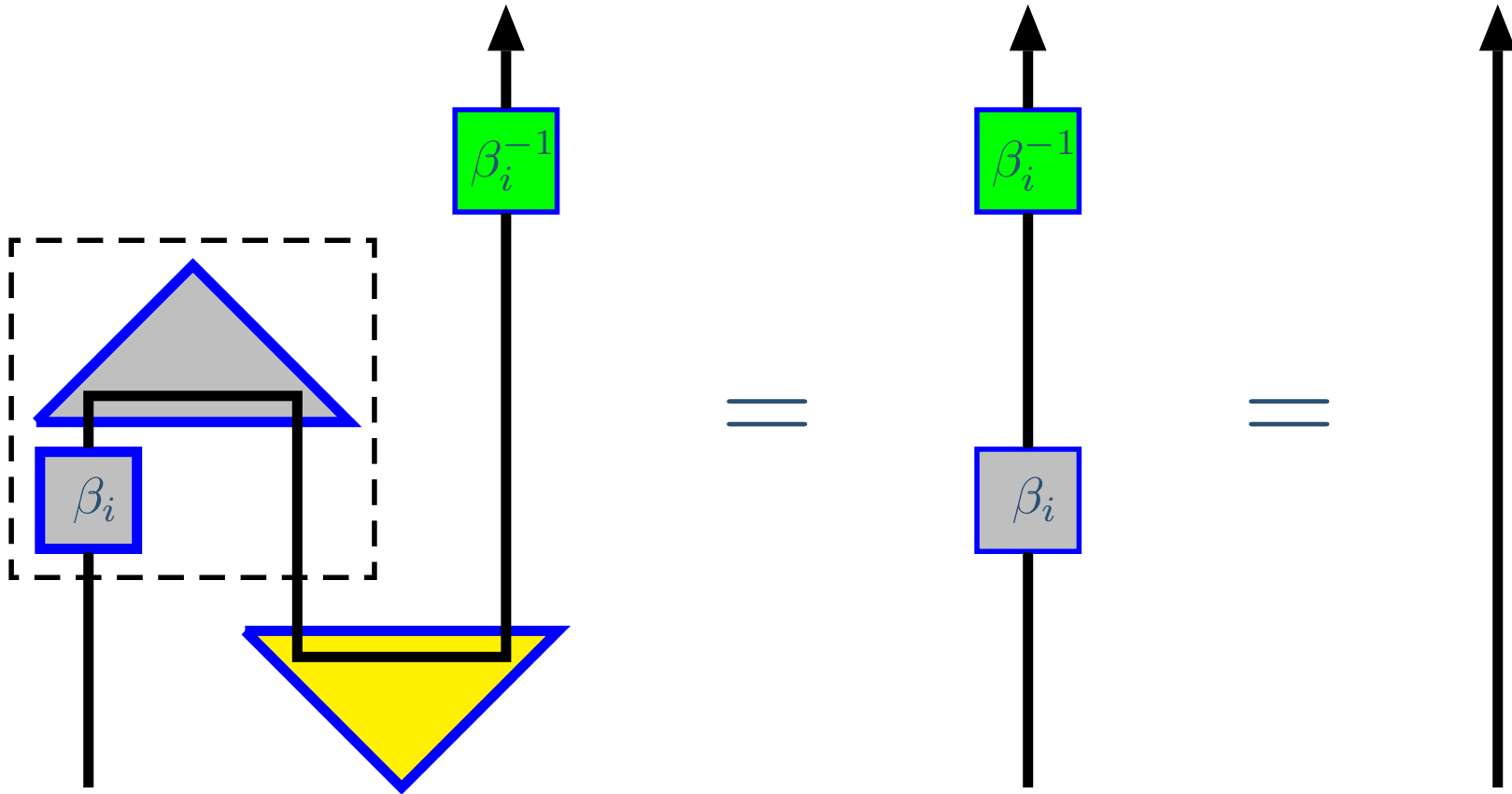



Further Developments

◻ Title

◻ Overview

Introduction to Quantum
Mechanics

Entanglement

Categorical Quantum
Mechanics

The Graphical Calculus

Conclusions

◻ Further Developments

◻ It's Logic!

◻ Temperley-Lieb Algebra

◻ Connections with Knots:
the Kauffman bracket

◻ Some Papers

The setting is very rich:

- ▲ compound systems, unitary operations, projectors, preparations of entangled states, Dirac bra-ket notation, traces, scalars, the Born rule, Hilbert-Schmidt norm, etc.
- ▲ dictionary of interpretation of QM concepts in the abstract setting



Further Developments

◊ Title

◊ Overview

Introduction to Quantum
Mechanics

Entanglement

Categorical Quantum
Mechanics

The Graphical Calculus

Conclusions

◊ Further Developments

◊ It's Logic!

◊ Temperley-Lieb Algebra

◊ Connections with Knots:
the Kauffman bracket

◊ Some Papers

The setting is very rich:

- ▲ compound systems, unitary operations, projectors, preparations of entangled states, Dirac bra-ket notation, traces, scalars, the Born rule, Hilbert-Schmidt norm, etc.
- ▲ dictionary of interpretation of QM concepts in the abstract setting

Recently, Peter Selinger has shown how this axiomatic setting elegantly accomodates the standard Quantum Information setting of completely positive maps acting on generalized states (density operators). In fact, there is a general construction which can be performed at the abstract level, which specializes to the passage from linear operators on Hilbert spaces to completely positive maps acting on density operators.



It's Logic!

- ◊ Title
- ◊ Overview
- Introduction to Quantum Mechanics
- Entanglement
- Categorical Quantum Mechanics
- The Graphical Calculus
- Conclusions
- ◊ Further Developments
- ◊ It's Logic!
- ◊ Temperley-Lieb Algebra
- ◊ Connections with Knots:
 - the Kauffman bracket
- ◊ Some Papers

The graphical calculus can be seen as a *calculus of proofs* for a certain *logic* — which is highly non-classical, (in particular *resource-sensitive*, so e.g. it builds in ‘No Cloning’), but also very different from the Birkhoff-von Neumann quantum logic.

Simplification of diagrams — ‘straightening out the lines’ — corresponds to *normalization* or *cut-elimination* of proofs. (SA and Ross Duncan, Categorical Quantum Logic, and Ross’s forthcoming thesis).



Temperley-Lieb Algebra

Generators:

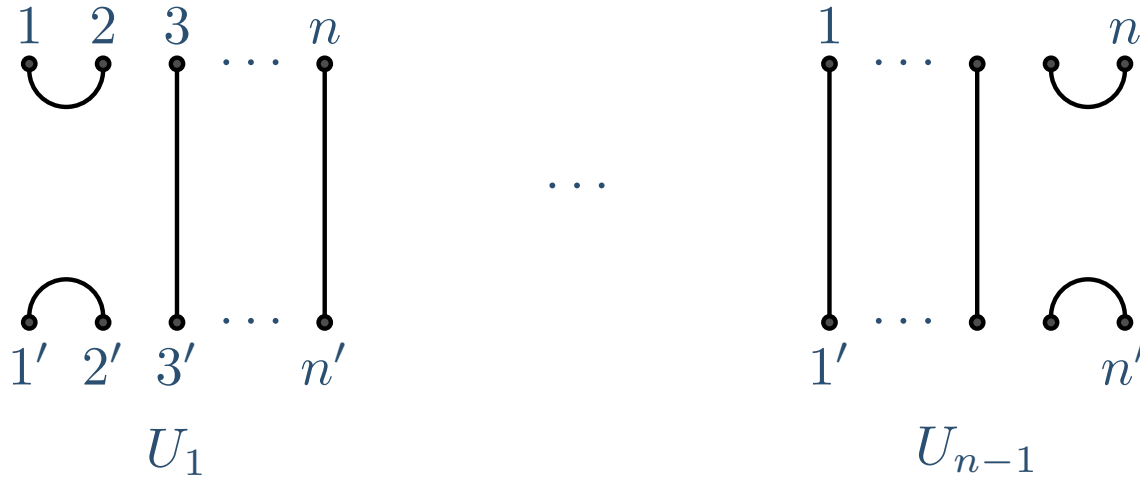



Temperley-Lieb Algebra

Generators:

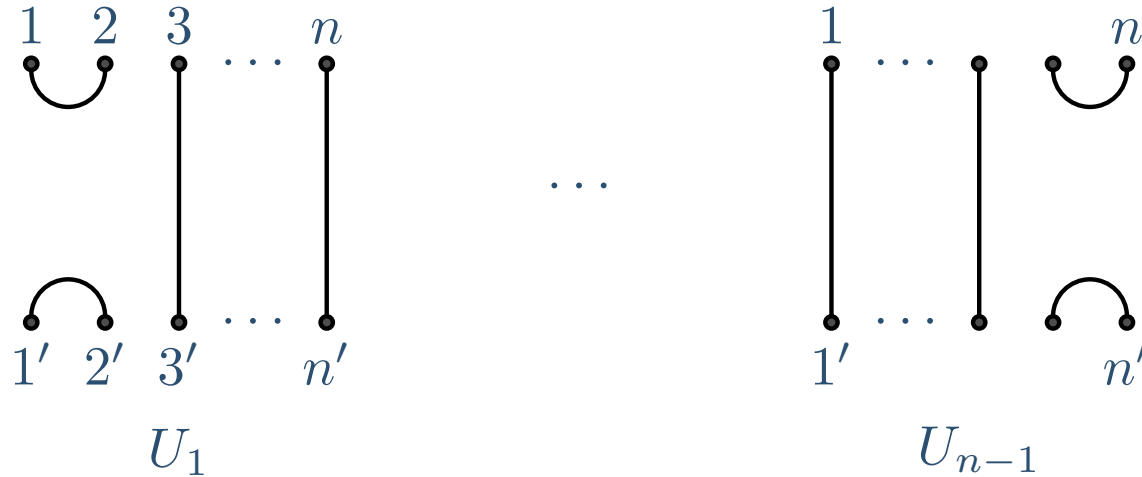

Relations:

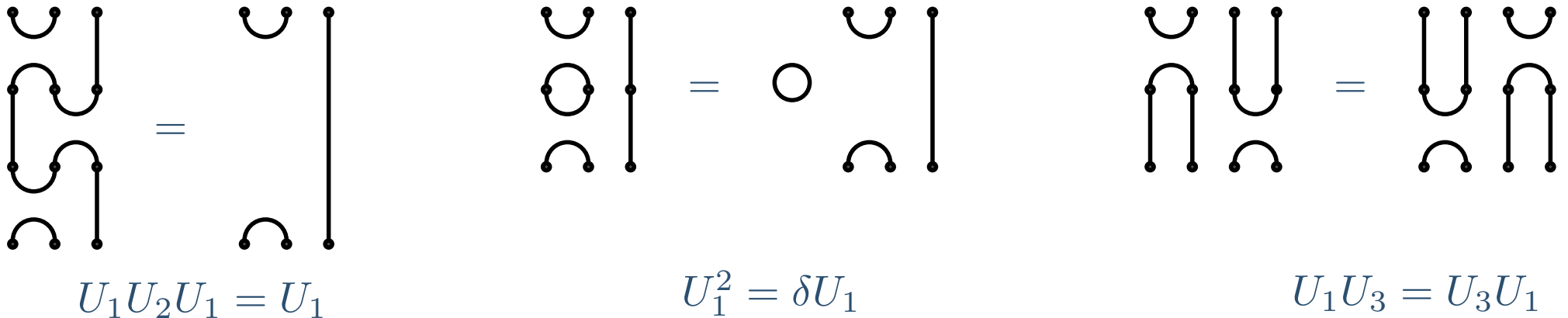



Connections with Knots: the Kauffman bracket

◊ Title

◊ Overview

Introduction to Quantum
Mechanics

Entanglement

Categorical Quantum
Mechanics

The Graphical Calculus

Conclusions

◊ Further Developments

◊ It's Logic!

◊ Temperley-Lieb Algebra

◊ Connections with Knots:

the Kauffman bracket

◊ Some Papers

The Temperley-Lieb algebra carries a representation of the braid group. The trace of the image of a braid yields a scalar — the Jones polynomial of the corresponding link (with appropriate choices for A and B and a normalizing factor to give invariance under the first Reidemeister move). This lifts to yield 3-manifold invariants and 3-D TQFT's.

Temperley-Lieb algebras are free (non-symmetric) strongly compact closed categories over one self-dual generator. We can also apply ideas from TCS, Logic to yield the first direct (no quotients) purely combinatorial description of the Temperley-Lieb algebra.



Some Papers

Papers available from the `arXiv` or my webpages

<http://web.comlab.ox.ac.uk/oucl/work/samson.abramsky/>

- ▲ Abramsky, S. and Coecke, B. (2004) *A categorical semantics of quantum protocols*. Proceedings of the 19th Annual IEEE Symposium on Logic in Computer Science (LiCS'04), IEEE Computer Science Press. (extended version at `arXiv: quant-ph/0402130`)
- ▲ Abramsky, S. and Duncan, R. W. (2004) *Categorical Quantum Logic*. To appear in *Mathematical Structures in Computer Science*, 2006.
- ▲ Abramsky, S. and Coecke, B. (2005) *Abstract Physical Traces*. *Theory and Applications of Categories* 14:111–124, 2005.
- ▲ Abramsky, S. (2005) *Abstract Scalars, Loops, and Free Traced and Strongly Compact Closed Categories*. In *Proceedings of CALCO 2005*, Springer Lecture Notes in Computer Science Vol. 3629, 1–31, 2005.
- ▲ S. Abramsky, R. F. Blute and P. Panangaden (1999). Nuclear and trace ideals in tensor $*$ -categories. *Journal of Pure and Applied Algebra* 143, 3–47, 1999.