

---

# On axiomatising products of Kripke frames, part II

AGI KURUCZ

---

ABSTRACT. We generalise some results of [7, 5] and show that if  $L$  is an  $\alpha$ -modal logic (for some ordinal  $\alpha \geq 3$ ) such that (i)  $L$  contains the product logic  $\mathbf{K}^\alpha$  and (ii) the product of  $\alpha$ -many trees of depth one and with arbitrary large finite branching is a frame for  $L$ , then any axiomatisation of  $L$  must contain infinitely many propositional variables. As a consequence we obtain that product logics like  $\mathbf{K}^\alpha$ ,  $\mathbf{K4}^\alpha$ ,  $\mathbf{S4}^\alpha$ ,  $\mathbf{GL}^\alpha$ , and  $\mathbf{Grz}^\alpha$  cannot be axiomatised using finitely many propositional variables, whenever  $\alpha \geq 3$ .

**Keywords:** many-dimensional modal logic, axiomatisation

## 1 Introduction and results

We consider the problem whether certain propositional  $\alpha$ -modal logics can be axiomatised by a (possibly infinite) set of  $\alpha$ -modal formulas containing only finitely many propositional variables altogether. By an  $\alpha$ -modal formula, for any non-zero ordinal  $\alpha$ , we mean any formula built up from propositional variables using the Booleans and the modal operators  $\diamond_\beta$  and  $\square_\beta$  for  $\beta < \alpha$ . A set  $L$  of  $\alpha$ -modal formulas is called a (normal)  $\alpha$ -modal logic if it contains all propositional tautologies and the formulas  $\square_\beta(p \rightarrow q) \rightarrow (\square_\beta p \rightarrow \square_\beta q)$ , for  $\beta < \alpha$ , and is closed under the rules of Substitution, Modus Ponens and Necessitation  $\varphi/\square_\beta\varphi$ , for  $\beta < \alpha$ . Given an  $\alpha$ -modal logic  $L$  and a set  $\Sigma$  of  $\alpha$ -modal formulas, we say that  $\Sigma$  axiomatises  $L$  if  $L$  is the smallest  $\alpha$ -modal logic containing  $\Sigma$ .

In what follows we assume that the reader is familiar with the basics of possible world semantics for multimodal logics (see e.g. [2]). The  $\alpha$ -modal logics we deal with are ‘ $\alpha$ -dimensional’ in the sense that they have among their frames  $\alpha$ -dimensional product frames: The product of 1-frames  $\mathfrak{F}_\beta = (W_\beta, R_\beta)$ ,  $\beta < \alpha$  is the  $\alpha$ -frame  $\mathfrak{F} = (W, \bar{R}_\beta)_{\beta < \alpha}$ , where  $W$  is the Cartesian product of the  $W_\beta$ ,  $\beta < \alpha$ , and for each  $\beta < \alpha$ ,  $\bar{R}_\beta$  is the following binary relation on  $W$ :

$$(u_\gamma)_{\gamma < \alpha} \bar{R}_\beta (v_\gamma)_{\gamma < \alpha} \text{ iff } u_\beta R_\beta v_\beta \text{ and } u_\gamma = v_\gamma, \text{ for } \gamma \neq \beta < \alpha.$$

For finite  $\alpha$ , we will use the notation  $\mathfrak{F} = \mathfrak{F}_0 \times \cdots \times \mathfrak{F}_{\alpha-1}$ . The product of Kripke complete unimodal logics  $L_\beta$ ,  $\beta < \alpha$  is the  $\alpha$ -modal logic determined by the class of all those  $\alpha$ -dimensional product frames whose  $\beta$ th component is a frame for  $L_\beta$ , for each  $\beta < \alpha$ . For example,  $\mathbf{K}^\alpha$  is the  $\alpha$ -modal logic

of all  $\alpha$ -dimensional product frames, and  $\mathbf{S5}^\alpha$  is that of all  $\alpha$ -dimensional products of equivalence relation frames. Products of modal logics were introduced by Segerberg [10] and Shehtman [11] and have been extensively studied, see [2] for further references and [8] for a more recent survey.

It is not hard to show (see e.g. [8]) that product logics of any dimension are recursively enumerable whenever for each component logic the class of its frames is definable by a recursive set of first-order sentences. Gabbay and Shehtman [3] showed that many 2-dimensional product logics ( $\mathbf{K}^2$  and  $\mathbf{S5}^2$  among them) and products of  $\mathbf{Alt}$  (the logic of functional frames) in any finite dimension are finitely axiomatisable. For higher dimensions, that is, for  $\alpha \geq 3$ , no other ‘positive’ axiomatisation result is known. On the ‘negative’ side, the non-finite axiomatisability of  $\mathbf{S5}^\alpha$  was proved by Johnson [6] and that of  $\mathbf{K}^\alpha$  by Kurucz [7]. These results were generalised by Hirsch *et al.* [5] who showed that no  $\alpha$ -modal logic between  $\mathbf{K}^\alpha$  and  $\mathbf{S5}^\alpha$  can be axiomatised finitely. Here we show that, for many of these logics, any axiomatisation actually must contain infinitely many propositional variables.

Throughout, an  $n$ -fan (for  $n < \omega$ ) is a unimodal (reflexive or irreflexive) tree of depth 1 having  $n$  leaves (see Figure 1).



Figure 1. Reflexive and irreflexive 4-fans

**THEOREM 1.** *Let  $\alpha \geq 3$  and  $L$  be any  $\alpha$ -modal logic containing  $\mathbf{K}^\alpha$ . If the product of  $\alpha$  arbitrarily large finite fans is a frame for  $L$ , then  $L$  is not axiomatisable using finitely many propositional variables.*

Well-known examples of modal logics having fans among their frames are  $\mathbf{K}$ ,  $\mathbf{K4}$  (the logic of transitive frames),  $\mathbf{S4}$  (the logic of reflexive and transitive frames),  $\mathbf{GL}$  (the logic of irreflexive and transitive frames without infinite ascending chains),  $\mathbf{Grz}$  (the logic of reflexive and transitive frames without infinite ascending chains of distinct points), so we have the following:

**COROLLARY 2.** *None of the logics  $\mathbf{K}^\alpha$ ,  $\mathbf{K4}^\alpha$ ,  $\mathbf{S4}^\alpha$ ,  $\mathbf{GL}^\alpha$ ,  $\mathbf{Grz}^\alpha$  is axiomatisable using finitely many propositional variables, whenever  $\alpha \geq 3$ .*

Theorem 1 does not apply to product logics where some components have transitive frames with some restriction on their width. An important example of this kind is  $\mathbf{S5}^\alpha$ . Johnson’s [6] non-finite axiomatisability result was obtained in an algebraic setting: he proved that the modal algebras corresponding to  $\mathbf{S5}^\alpha$  (*representable diagonal-free cylindric algebras of dimension  $\alpha$* ) have a non-finitely axiomatisable equational theory, whenever  $\alpha \geq 3$ . Representable cylindric algebras of dimension  $\alpha$  (modal algebras of  $\mathbf{S5}^\alpha$  plus diagonal constants) have been extensively studied in algebraic logic. Strengthening earlier results of Monk [9], Andr eka [1] proved (among

other strong non-finitisability properties) that any possible axiomatisation of their equational theory must contain infinitely many variables, if  $\alpha \geq 3$ . She also left open, however, whether one needed infinitely many variables in the diagonal-free case.

The rest of the paper is devoted to the proof of Theorem 1. To begin with, given  $m < \omega$ , we call a modal model  $\mathfrak{M} = (\mathfrak{F}, \vartheta)$  *m-generated* if there are at most  $m$  different propositional variables  $p$  such that  $\vartheta(p) \neq \emptyset$ . We plan to proceed as follows. For every  $0 < k < \omega$ , we will define an  $\alpha$ -frame  $\mathfrak{F}_k$  such that:

- (a) If  $2k > 2^m$  then  $\mathfrak{M} \models L$  for every  $m$ -generated model  $\mathfrak{M}$  based on  $\mathfrak{F}_k$ .
- (b)  $\mathfrak{F}_k \not\models \mathbf{K}^\alpha$ .

This will prove Theorem 1 because of the following. Suppose that  $\Sigma$  axiomatises  $L$  and  $\Sigma$  contains  $m$  propositional variables, for some  $m < \omega$ . Let  $2k > 2^m$  and take an  $\alpha$ -frame  $\mathfrak{F}_k$  satisfying (a). Let  $\mathfrak{M}$  be an arbitrary model based on  $\mathfrak{F}_k$ . Let  $\mathfrak{M}_m$  be another model over  $\mathfrak{F}_k$  that is the same as  $\mathfrak{M}$  on propositional variables occurring in  $\Sigma$ , and  $\emptyset$  otherwise. Then  $\mathfrak{M}_m$  is clearly  $m$ -generated and  $\mathfrak{M}_m \models \Sigma$  iff  $\mathfrak{M} \models \Sigma$ . So by (a), we have  $\mathfrak{M}_m \models L$ . As  $\Sigma \subseteq L$ , we obtain  $\mathfrak{M}_m \models \Sigma$ , and so  $\mathfrak{M} \models \Sigma$ . This holds for any model  $\mathfrak{M}$  over  $\mathfrak{F}_k$ , so  $\mathfrak{F}_k \models \Sigma$  follows. Therefore,  $\{\varphi : \mathfrak{F}_k \models \varphi\}$  is an  $\alpha$ -modal logic containing  $\Sigma$ , and so we have  $\mathfrak{F}_k \models L$ . As  $\mathbf{K}^\alpha \subseteq L$ , this implies  $\mathfrak{F}_k \models \mathbf{K}^\alpha$ , contradicting (b).

## 2 Frames

In this section we construct the  $\alpha$ -frames  $\mathfrak{F}_k$  via some steps, and show that they have property (a). To make things clearer, we make two simplifications. First, we work with  $\alpha = 3$  and then explain how to extend everything to any  $\alpha \geq 3$  (see Remark 7). And second, we deal with products of irreflexive fans only and then, also in Remark 7, we explain how to extend the proof to the reflexive cases. In drawing ‘three-dimensional’ pictures of 3-frames, we adopt the following convention in drawing three accessibility relations:

$$\begin{array}{c} R_1 \uparrow \nearrow R_2 \\ \xrightarrow{R_0} \end{array}$$

Fix some  $0 < k < \omega$ . We define a (rooted) 3-frame  $\mathfrak{G}_k = (G, R_0^\mathfrak{G}, R_1^\mathfrak{G}, R_2^\mathfrak{G})$  as follows (see also Figure 2):

$$\begin{aligned} G &= \{r_{000}, d_{010}, d_{001}, d_{110}, d_{101}, i_{011}, i_{100}, i_{111}^1, i_{111}^2\}_{i < k} \\ R_0^\mathfrak{G} &= \{(r_{000}, i_{100}), (d_{010}, d_{110}), (d_{001}, d_{101}), (i_{011}, i_{111}^1), (i_{011}, i_{111}^2)\}_{i < k} \\ R_1^\mathfrak{G} &= \{(r_{000}, d_{010}), (i_{100}, d_{110}), (d_{001}, i_{011}), (d_{101}, i_{111}^1), (d_{101}, i_{111}^2)\}_{i < k} \\ R_2^\mathfrak{G} &= \{(r_{000}, d_{001}), (i_{100}, d_{101}), (d_{010}, i_{011}), (d_{110}, i_{111}^1), (d_{110}, i_{111}^2)\}_{i < k} \end{aligned}$$

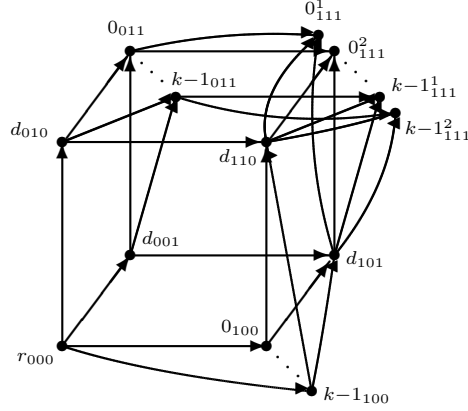
Figure 2. The 3-frame  $\mathfrak{G}_k$ .

Recall that, given two 3-frames  $\mathfrak{H} = (W, S_i^{\mathfrak{H}})_{i < 3}$  and  $\mathfrak{G} = (V, S_i^{\mathfrak{G}})_{i < 3}$ , a function  $f : W \rightarrow V$  is called a *p-morphism* from  $\mathfrak{H}$  to  $\mathfrak{G}$ , if for all  $u, v \in W$ ,  $i < 3$ ,  $uS_i^{\mathfrak{H}}v$  implies  $f(u)S_i^{\mathfrak{G}}f(v)$  (*forward condition*), and for all  $x \in V$ ,  $i < 3$ , the following

$$BC_i(x) : \quad \forall u \in W, y \in V (f(u) = x \text{ and } xS_i^{\mathfrak{G}}y \implies \exists v \in W, uS_i^{\mathfrak{H}}v \text{ and } f(v) = y)$$

hold (*backward condition*). If  $f$  is onto then we say that  $\mathfrak{G}$  is a *p-morphic image* of  $\mathfrak{H}$ . It is a well-known property that the validity of modal formulas in frames is preserved under taking p-morphic images.

Below we show that  $\mathfrak{G}_k$  is a p-morphic image of a product of finite fans. To this end, for any  $n < \omega$ , consider the irreflexive  $n$ -fan  $\mathfrak{H}_n = (H_n, R^{\mathfrak{H}_n})$ , where  $H_n = \{u, z_0, \dots, z_{n-1}\}$  and  $R^{\mathfrak{H}_n} = \{(u, z_0), \dots, (u, z_{n-1})\}$ .

CLAIM 3.  $\mathfrak{G}_k$  is a p-morphic image of  $\mathfrak{H}_k \times \mathfrak{H}_{2k} \times \mathfrak{H}_{2k}$ .

**Proof.** For all  $j, \ell < 2k$ , let  $(j +_k \ell)$  denote the sum of  $j$  and  $\ell$  modulo  $k$ . We define a function  $g$  on  $H_k \times H_{2k} \times H_{2k}$  as follows, for all  $i < k$ ,  $j, \ell < 2k$  (see also Figure 3 where each point in  $H_k \times H_{2k} \times H_{2k}$  is labelled with its  $g$ -image):

$$g(z_i, z_j, z_\ell) = \begin{cases} (j +_k \ell)_{111}^1, & \text{if } i \text{ is odd and either } j, \ell < k \\ & \text{or } k \leq j, \ell < 2k, \\ (j +_k \ell)_{111}^1, & \text{if } i \text{ is even and either } j < k \leq \ell < 2k, \\ & \text{or } \ell < k \leq j < 2k, \\ (j +_k \ell)_{111}^2, & \text{if } i \text{ is even and either } j, \ell < k \\ & \text{or } k \leq j, \ell < 2k, \\ (j +_k \ell)_{111}^2, & \text{if } i \text{ is odd and either } j < k \leq \ell < 2k, \\ & \text{or } \ell < k \leq j < 2k, \end{cases}$$

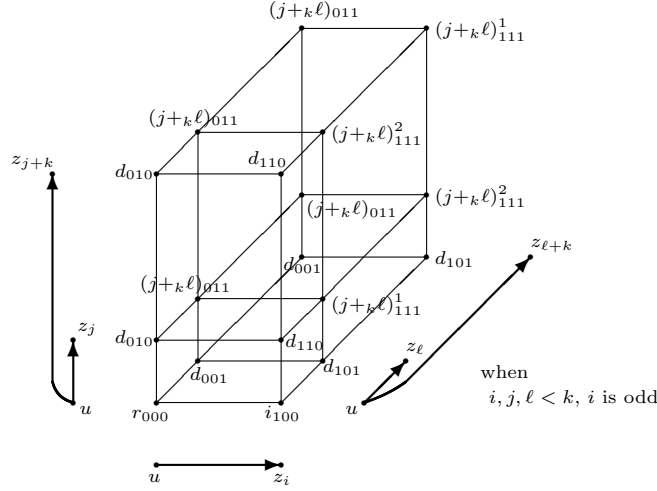
Figure 3. The p-morphism  $g : \mathfrak{H}_k \times \mathfrak{H}_{2k} \times \mathfrak{H}_{2k} \rightarrow \mathfrak{G}_k$ .

$$\begin{aligned}
g(u, u, u) &= r_{000}, & g(z_i, u, u) &= i_{100}, \\
g(u, u, z_\ell) &= d_{001}, & g(u, z_j, u) &= d_{010}, \\
g(z_i, u, z_\ell) &= d_{101}, & g(z_i, z_j, u) &= d_{110}, \\
g(u, z_j, z_\ell) &= (j+k\ell)_{011}.
\end{aligned}$$

A tedious but straightforward computation shows that  $g$  is a p-morphism from  $\mathfrak{H}_k \times \mathfrak{H}_{2k} \times \mathfrak{H}_{2k}$  onto  $\mathfrak{G}_k$ . Here we go through two of the trickiest cases. For  $BC_2(d_{110})$ , we need to show that for all  $i < k$ ,  $j < 2k$ ,  $n < k$ , there exist  $\ell_1, \ell_2 < 2k$  such that  $g(z_i, z_j, z_{\ell_1}) = n_{111}^1$  and  $g(z_i, z_j, z_{\ell_2}) = n_{111}^2$ . Given such  $i, j, n$ , we always have an  $s < k$  such that  $s + k j = n$ . Now if either  $i$  is odd and  $j < k$ , or  $i$  is even and  $k \leq j < 2k$ , then  $\ell_1 = s$  and  $\ell_2 = s + k$  will do. In any other case, take  $\ell_1 = s + k$  and  $\ell_2 = s$ .

For  $BC_0(n_{011})$ ,  $n < k$ , we need to show that for all  $j, \ell < 2k$  such that  $j + k \ell = n$  there exist  $i_1, i_2 < k$  such that  $g(z_{i_1}, z_j, z_\ell) = n_{111}^1$  and  $g(z_{i_2}, z_j, z_\ell) = n_{111}^2$ . Now if either  $j, \ell < k$  or  $k \leq j, \ell < 2k$  then choose  $i_1 < k$  to be odd and  $i_2 < k$  to be even. In any other case, choose  $i_1 < k$  to be even and  $i_2 < k$  to be odd. ■

Next, we ‘ruin’  $\mathfrak{G}_k$  a bit by adding some more points and arrows to it. We define the 3-frame  $\mathfrak{F}_k = (F, R_0^{\mathfrak{F}}, R_1^{\mathfrak{F}}, R_2^{\mathfrak{F}})$  as follows (see also Figure 4):

$$\begin{aligned}
F &= G \cup \{a_{010}, a_{001}, i_{110}, i_{101}\}_{i < k} \\
R_0^{\mathfrak{F}} &= R_0^{\mathfrak{G}} \cup \{(a_{010}, i_{110}), (a_{001}, i_{101})\}_{i < k} \\
R_1^{\mathfrak{F}} &= R_1^{\mathfrak{G}} \cup \{(r_{000}, a_{010}), (i_{100}, i_{110}), (a_{001}, i_{011}), \\
&\quad (i_{101}, j_{111}^2), (i_{101}, \ell_{111}^1)\}_{i, j, \ell < k, \ell \neq i} \\
R_2^{\mathfrak{F}} &= R_2^{\mathfrak{G}} \cup \{(r_{000}, a_{001}), (i_{100}, i_{101}), (a_{010}, i_{011}), \\
&\quad (i_{110}, j_{111}^1), (i_{110}, \ell_{111}^2)\}_{i, j, \ell < k, \ell \neq i}
\end{aligned}$$

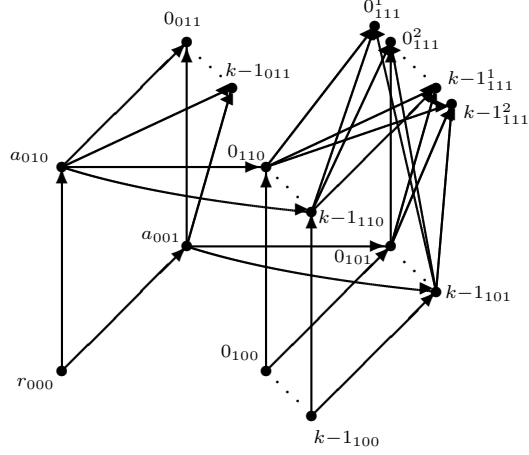

Figure 4. The arrows in  $\mathfrak{F}_k$  that are not present in  $\mathfrak{G}_k$ .

Though, as we shall see in Section 3,  $\mathfrak{F}_k \not\cong \mathbf{K}^3$  and so it cannot be a p-morphic image of any product frame, it is ‘almost’ such:

CLAIM 4.  $\mathfrak{F}_k$  is a p-morphic image of a subframe  $\mathfrak{H}$  of  $\mathfrak{H}_k \times \mathfrak{H}_{2k+1} \times \mathfrak{H}_{2k+1}$ .

**Proof.** We give a proof for  $k \geq 4$  only (for  $k = 3$  a slightly different function would work). Let

$$H = (H_k \times H_{2k+1} \times H_{2k+1}) - (H_k \times \{z_{2k}\} \times \{z_{2k}\}),$$

and let  $\mathfrak{H}$  be the subframe of  $\mathfrak{H}_k \times \mathfrak{H}_{2k+1} \times \mathfrak{H}_{2k+1}$  having  $H$  as its domain. Take the p-morphism  $g : \mathfrak{H}_k \times \mathfrak{H}_{2k} \times \mathfrak{H}_{2k} \rightarrow \mathfrak{G}_k$  defined in the proof of Claim 3. We define a function  $g^+$  on  $H$  such that  $g^+$  is an extension of  $g$ , that is, for every  $x \in H_k \times H_{2k} \times H_{2k}$ ,  $g^+(x) = g(x)$ .

For the ‘new’ points we define  $g^+$  as follows, for all  $i < k$ ,  $j < 2k$  (see also Figure 5):

$$\begin{aligned} g^+(u, z_{2k}, u) &= a_{010}, & g^+(u, u, z_{2k}) &= a_{001}, \\ g^+(u, z_{2k}, z_j) &= g^+(u, z_j, z_{2k}) = \begin{cases} j_{011}, & \text{if } j < k, \\ (j-k)_{011}, & \text{if } k \leq j < 2k, \end{cases} \\ g^+(z_i, z_{2k}, u) &= i_{110}, & g^+(z_i, u, z_{2k}) &= i_{101}, \\ g^+(z_i, z_{2k}, z_j) &= \begin{cases} j_{111}^1, & \text{if } i = j \text{ or } i = j - k, \\ j_{111}^1, & \text{if } i \neq j, i \text{ is odd and } j < k, \\ (j-k)_{111}^1, & \text{if } i \neq j - k, i \text{ is even and } k \leq j < 2k, \\ j_{111}^2, & \text{if } i \neq j, i \text{ is even and } j < k, \\ (j-k)_{111}^2, & \text{if } i \neq j - k, i \text{ is odd and } k \leq j < 2k, \end{cases} \\ g^+(z_i, z_j, z_{2k}) &= \begin{cases} j_{111}^2, & \text{if } i = j \text{ or } i = j - k, \\ j_{111}^2, & \text{if } i \neq j, i \text{ is odd and } j < k, \\ (j-k)_{111}^2, & \text{if } i \neq j - k, i \text{ is even and } k \leq j < 2k, \\ j_{111}^1, & \text{if } i \neq j, i \text{ is even and } j < k, \\ (j-k)_{111}^1, & \text{if } i \neq j - k, i \text{ is odd and } k \leq j < 2k. \end{cases} \end{aligned}$$

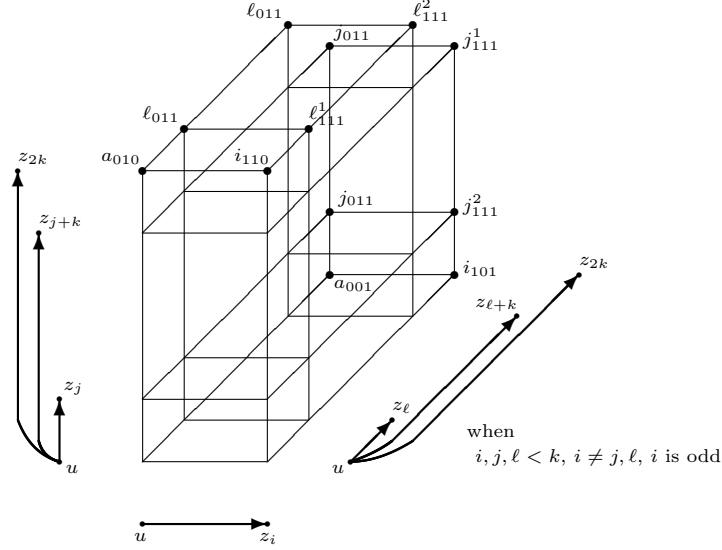
Figure 5. The p-morphism  $g^+ : \mathfrak{H} \rightarrow \mathfrak{F}_k$  on the ‘new’ points.

Then it is straightforward to show that  $g^+$  is a p-morphism from  $\mathfrak{H}$  onto  $\mathfrak{F}_k$ . Here we give two sample cases only. As concerns  $BC_0(i_{011})$ , for each  $i < k$ , we have four new pre-images of  $i_{011}$ :  $(u, z_i, z_{2k})$ ,  $(u, z_{i+k}, z_{2k})$ ,  $(u, z_{2k}, z_i)$ , and  $(u, z_{2k}, z_{i+k})$ . Take first  $(u, z_i, z_{2k})$ . We need to show that there exist  $j_1, j_2 < k$  such that  $g^+(z_{j_1}, z_i, z_{2k}) = i_{111}^1$  and  $g^+(z_{j_2}, z_i, z_{2k}) = i_{111}^2$ . Now if  $k \geq 4$  then we can choose  $j_1 < k$  to be even and different from  $i$  and  $j_2 < k$  to be odd. For  $(u, z_{i+k}, z_{2k})$ , we need to show that there exist  $j_1, j_2 < k$  such that  $g^+(z_{j_1}, z_{i+k}, z_{2k}) = i_{111}^1$  and  $g^+(z_{j_2}, z_{i+k}, z_{2k}) = i_{111}^2$ . To this end, choose  $j_1 < k$  to be odd and different from  $i$  and  $j_2 < k$  to be even. The other two cases are similar.

For  $BC_2(i_{110})$ ,  $i < k$  we need to show that for all  $n < k$  there exists  $j_1 < 2k$  such that  $g(z_i, z_{2k}, z_{j_1}) = n_{111}^1$ , for all  $n < k, n \neq i$ , there exists  $j_1 < 2k$  such that  $g(z_i, z_{2k}, z_{j_2}) = n_{111}^2$ . Now if  $i = n$  then take  $j_1 = n$ . If  $i \neq n$  and  $i$  is odd then take  $j_1 = n$  and  $j_2 = n + k$ , and if  $i \neq n$  and  $i$  is even then take  $j_1 = n + k$  and  $j_2 = n$ . ■

CLAIM 5. Let  $\mathfrak{F}$  be a 3-frame, and suppose that  $f : \mathfrak{F}_k \rightarrow \mathfrak{F}$  is an onto p-morphism such that  $f(i_{111}^m) = f(j_{111}^n)$  for some  $i \neq j$  or  $n \neq m$ . Then  $\mathfrak{F}$  is a p-morphic image of  $\mathfrak{H}_k \times \mathfrak{H}_{2k+1} \times \mathfrak{H}_{2k+1}$ .

**Proof.** We again give a proof for  $k \geq 4$  only (for  $k = 3$  a slightly different function would work). Take the p-morphism  $g^+ : \mathfrak{H} \rightarrow \mathfrak{F}_k$  defined in the proof of Claim 4. We define a function  $h$  on  $H_k \times H_{2k+1} \times H_{2k+1}$  such that  $h$  is an extension of  $g^+ \circ f$ , that is, for every  $x \in H$ ,  $h(x) = fg^+(x)$ .

Let  $i, j, m, n$  be as in the assumption of the claim. For the ‘new’ points

we define  $h$  as follows:

$$h(u, z_{2k}, z_{2k}) = f(i_{011}),$$

$$h(z_\ell, z_{2k}, z_{2k}) = \begin{cases} f(i_{111}^m) = f(j_{111}^n), & \text{if } \ell = i, \\ f(i_{111}^1), & \text{if } \ell < k, \ell \neq i \text{ and } \ell \text{ is odd,} \\ f(i_{111}^2), & \text{if } \ell < k, \ell \neq i \text{ and } \ell \text{ is even.} \end{cases}$$

It is straightforward to check that  $h$  is a p-morphism from  $\mathfrak{H}_k \times \mathfrak{H}_{2k+1} \times \mathfrak{H}_{2k+1}$  onto  $\mathfrak{F}$ . Here is the trickiest case only. For  $BC_0(f(i_{011}))$ , there is no problem with the ‘old’  $h$ -pre-images of  $f(i_{011})$  (those that are in  $H$ ), as the composition of p-morphisms is a p-morphism. As concerns the only new one,  $(u, z_{2k}, z_{2k})$ , we need to show that there exist  $j_1, j_2 < k$  such that  $h(z_{j_1}, z_{2k}, z_{2k}) = f(i_{111}^1)$  and  $h(z_{j_2}, z_{2k}, z_{2k}) = f(i_{111}^2)$ . Now if  $k \geq 4$  then we can choose both  $j_1$  and  $j_2$  to be different from  $i$  and such that  $j_1 < k$  is odd and  $j_2 < k$  is even.  $\blacksquare$

Now we can show that  $\mathfrak{F}_k$  satisfies property (a):

LEMMA 6. *Let  $L$  be a 3-modal logic such that  $\mathfrak{H}_k \times \mathfrak{H}_{2k+1} \times \mathfrak{H}_{2k+1} \models L$  for some  $k < \omega$ . If  $2k > 2^m$  then  $\mathfrak{M} \models L$  for every  $m$ -generated model  $\mathfrak{M}$  over  $\mathfrak{F}_k$ .*

**Proof.** Fix some  $k, m$  with  $2k > 2^m$ . Let  $\mathfrak{M} = (\mathfrak{F}_k, \vartheta)$  be such that  $\vartheta(p_j) = \emptyset$  for every propositional variable  $p_j$  with  $j \geq m$ .

We call two points in  $\mathfrak{F}_k$   $\equiv$ -equivalent iff no 3-modal formula can distinguish them in  $\mathfrak{M}$ , that is, for all  $a, b \in F$ , we let

$$(1) \quad a \equiv b \iff (\forall \text{ formula } \varphi, \quad a \in \vartheta(\varphi) \iff b \in \vartheta(\varphi)).$$

For every  $a \in F$ , let  $[a]$  denote the  $\equiv$ -class of  $a$ , and let  $A = \{[a] : a \in F\}$ . We define a 3-frame  $\mathfrak{A}_{\mathfrak{M}} = (A, S_0, S_1, S_2)$  by taking, for  $i < 3$ ,

$$[a]S_i[b] \iff \exists a' \in [a], b' \in [b], a'R_i^{\mathfrak{F}_k}b'.$$

We claim that the function

$$f(a) = [a], \quad a \in F$$

is a p-morphism from  $\mathfrak{F}_k$  onto  $\mathfrak{A}_{\mathfrak{M}}$ . This is a straightforward consequence of duality theory and the finiteness of  $\mathfrak{F}_k$ , but we give a short direct proof here. The forward condition holds by the definition of  $S_i$ . For the backward condition, observe that since  $\mathfrak{F}_k$  is finite, there are finitely many formulas  $\varphi_0, \dots, \varphi_{n-1}$  such that

$$(2) \quad a \equiv b \iff (\forall j < n, \quad a \in \vartheta(\varphi_j) \iff b \in \vartheta(\varphi_j))$$

(these  $\vartheta(\varphi_j)$  are the atoms of the algebra of  $\mathfrak{M}$ -definable subsets of  $F$ ). Now take some  $i < 3$ ,  $a, b \in F$  such that  $[a]S_i[b]$ , and let  $a' \in [a]$ . Then there are  $a'' \in [a]$ ,  $b'' \in [b]$  with  $a''R_i^{\mathfrak{F}_k}b''$ . Let  $\varphi$  be the ‘atomic type’ of  $b''$ , that is,

$$\varphi = \bigwedge_{j < n, b'' \in \vartheta(\varphi_j)} \varphi_j \quad \wedge \quad \bigwedge_{j < n, b'' \notin \vartheta(\varphi_j)} \neg \varphi_j.$$

Then  $b'' \in \vartheta(\varphi)$ . Therefore  $a'' \in \vartheta(\diamond_i \varphi)$ , and so  $a' \in \vartheta(\diamond_i \varphi)$ . So there is some  $b'$  such that  $a' R_i^{\mathfrak{F}} b'$  and  $b' \in \vartheta(\varphi)$ . Now  $b' \equiv b''$  follows by (2).

Next, define  $F_{111}$  as the subset of  $F$  containing all ‘dead ends’:

$$F_{111} = \{i_{111}^1, i_{111}^2\}_{i < k}.$$

We define an equivalence relation  $\equiv_m$  on  $F_{111}$  by taking, for all  $a, b \in F_{111}$ ,

$$a \equiv_m b \iff (\forall j < m, a \in \vartheta(p_j) \Leftrightarrow b \in \vartheta(p_j)).$$

Now recall the definition of  $\equiv$  from (1). An easy induction on formulas (using that  $a \notin \vartheta(\diamond_i \psi)$ , for any formula  $\psi$ ,  $a \in F_{111}$ ,  $i < 3$ ) shows that

$$(3) \quad \forall a, b \in F_{111}, (a \equiv_m b \implies a \equiv b).$$

As the cardinality of  $F_{111}$  is  $2k$  and there are  $2^m$  many  $\equiv_m$ -classes, by the pigeonhole principle and (3), there exist  $a \neq b \in F_{111}$  such that  $a \equiv b$ , and so  $f(a) = f(b)$ . Therefore, the 3-frame  $\mathfrak{A}_{\mathfrak{M}}$  and the p-morphism  $f$  satisfy the conditions of Claim 5, and so  $\mathfrak{A}_{\mathfrak{M}}$  is a p-morphic image of  $\mathfrak{H}_k \times \mathfrak{H}_{2k+1} \times \mathfrak{H}_{2k+1}$ . As by assumption  $\mathfrak{H}_k \times \mathfrak{H}_{2k+1} \times \mathfrak{H}_{2k+1} \models L$ , we obtain that  $\mathfrak{A}_{\mathfrak{M}} \models L$  as well. In particular,  $\mathfrak{M}' \models L$  for the model  $\mathfrak{M}' = (\mathfrak{A}_{\mathfrak{M}}, \vartheta')$  defined by taking, for each propositional variable  $p$ ,  $\vartheta'(p) = \{f(a) : a \in \vartheta(p)\}$ . As  $f$  is a p-morphism between models  $\mathfrak{M}$  and  $\mathfrak{M}'$ ,  $\mathfrak{M} \models L$  follows, as required. ■

REMARK 7. If  $\alpha \geq 3$  then we can extend the 3-frames  $\mathfrak{G}_k$  and  $\mathfrak{F}_k$  above to  $\alpha$ -frames by taking  $R_\beta^{\mathfrak{G}} = R_\beta^{\mathfrak{F}} = \emptyset$ , for  $3 \leq \beta < \alpha$ . Then in Claims 3–5 and Lemma 6 we should use  $\alpha$ -dimensional product frames, where the  $\beta$ th component is  $\mathfrak{H}_0 = (\{u\}, \emptyset)$  whenever  $3 \leq \beta < \alpha$ .

If the logic  $L$  in Theorem 1 is such that it has products of arbitrarily large finite fans among its frames, but some (or all) of these fans are reflexive, then in Claims 3–5 and Lemma 6 we have to define the corresponding relations in  $\mathfrak{G}_k$  and  $\mathfrak{F}_k$  and the corresponding ‘fan-components’ in the product frames to be reflexive as well. Then everything goes through with not much change in the arguments. In particular, when proving (3) above by induction on formulas, we need to use that if  $i$  is one of the ‘reflexive coordinates’ then for any formula  $\psi$  and any  $a \in F_{111}$ ,  $a \in \vartheta(\diamond_i \psi)$  iff  $a \in \vartheta(\psi)$ .

### 3 Formulas

In this section we prove property (b) of our frames, that is, that  $\mathfrak{F}_k \not\models \mathbf{K}^\alpha$ , for any  $0 < k < \omega$ . We do this by showing, for each  $k$ , a 3-modal formula that is valid in all  $\alpha$ -dimensional product frames but fails in  $\mathfrak{F}_k$ .

To this end, for each  $0 < k < \omega$ , we define  $\Phi_k$  to be the following first-order sentence of the language having binary predicates  $R_0$ ,  $R_1$  and  $R_2$  (see

also Figure 6):

$$\begin{aligned} \Phi_k : \quad & \forall vyzx_0 \dots x_{k-1} \left[ vR_1y \wedge vR_2z \wedge \bigwedge_{i < k} vR_0x_i \longrightarrow \right. \\ & \exists uy_0 \dots y_{k-1} z_0 \dots z_{k-1} u_0 \dots u_{k-1} \left( yR_2u \wedge zR_1u \wedge \right. \\ & \left. \left. \bigwedge_{i < k} (yR_0y_i \wedge zR_0z_i \wedge uR_0u_i \wedge x_iR_1y_i \wedge z_iR_1u_i \wedge x_iR_2z_i \wedge y_iR_2u_i) \right) \right]. \end{aligned}$$

Note that  $\Phi_1$  is the well-known ‘cubifying’ property of  $\geq 3$ -dimensional product frames (see [4, 3.2.68] and [7, 8]).

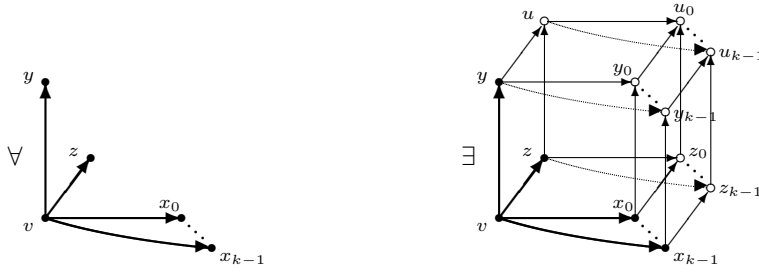

Figure 6. The first-order sentence  $\Phi_k$ .

It is easy to check the following claim.

CLAIM 8. For any  $0 < k < \omega$ ,  $\Phi_k$  is true in every  $\alpha$ -dimensional product frame.

These first-order properties are modally definable. Namely, for every  $0 < k < \omega$ , consider the following 3-modal formula  $\varphi_k$ :

$$\begin{aligned} & \left[ \diamond_1(\Box_0 p_{10} \wedge \Box_2 p_{12}) \wedge \diamond_2(\Box_0 p_{20} \wedge \Box_1 p_{21}) \wedge \bigwedge_{i < k} (\diamond_0(\Box_1 p_{01}^i \wedge \Box_2 p_{02}^i) \right. \\ & \left. \wedge \Box_0 \Box_1 (p_{01}^i \wedge p_{10} \rightarrow \Box_2 q_i) \wedge \Box_0 \Box_2 (p_{02}^i \wedge p_{20} \rightarrow \Box_1 r_i) \right] \\ & \longrightarrow \diamond_1 \diamond_2 (p_{12} \wedge p_{21} \wedge \bigwedge_{i < k} \diamond_0 (q_i \wedge r_i)). \end{aligned}$$

CLAIM 9. For every  $0 < k < \omega$  and every  $\alpha$ -frame  $\mathfrak{F}$ ,  $\Phi_k$  is true in  $\mathfrak{F}$  iff  $\mathfrak{F} \models \varphi_k$ .

**Proof.** We prove the harder right-to-left direction only. Fix some  $k$  and suppose that  $\mathfrak{F} = (W, S_\beta^\mathfrak{F})_{\beta < \alpha}$  is an  $\alpha$ -frame such that  $\mathfrak{F} \models \varphi_k$ . Let  $v, y, z, x_0, \dots, x_{k-1}$  in  $W$  be given as in  $\Phi_k$ . We define a model  $\mathfrak{M} = (\mathfrak{F}, \vartheta)$  over  $\mathfrak{F}$  as follows.

$$\begin{aligned} \vartheta(p_{01}^i) &= \{w \in W : x_i S_1^\mathfrak{F} w\}, & \vartheta(p_{02}^i) &= \{w \in W : x_i S_2^\mathfrak{F} w\}, & \text{for } i < k, \\ \vartheta(p_{10}) &= \{w \in W : y S_0^\mathfrak{F} w\}, & \vartheta(p_{12}) &= \{w \in W : y S_2^\mathfrak{F} w\}, \\ \vartheta(p_{20}) &= \{w \in W : z S_0^\mathfrak{F} w\}, & \vartheta(p_{21}) &= \{w \in W : z S_1^\mathfrak{F} w\}, \end{aligned}$$

$$\begin{aligned}\vartheta(q_i) &= \{w \in W : \exists s \in \vartheta(p_{01}^i) \cap \vartheta(p_{10}) sS_2^{\mathfrak{F}} w\}, \quad \text{for } i < k, \\ \vartheta(r_i) &= \{w \in W : \exists s \in \vartheta(p_{02}^i) \cap \vartheta(p_{20}) sS_1^{\mathfrak{F}} w\}, \quad \text{for } i < k.\end{aligned}$$

It is routine to check that the antecedent of  $\varphi_k$  holds in  $\mathfrak{M}$  at point  $v$ . Thus, by assumption,  $\diamond_1 \diamond_2 (p_{12} \wedge p_{21} \wedge \bigwedge_{i < k} \diamond_0 (q_i \wedge r_i))$  also holds in  $\mathfrak{M}$  at  $v$ . This implies that there are points  $u, u_0, \dots, u_{k-1}$  such that  $yS_2^{\mathfrak{F}} u$ ,  $zS_1^{\mathfrak{F}} u$ ,  $uS_0^{\mathfrak{F}} u_i$ , and  $q_i \wedge r_i$  holds in  $\mathfrak{M}$  at point  $u_i$ , for each  $i < k$ . By unfolding the definitions of  $\vartheta(q_i)$  and  $\vartheta(r_i)$ , we obtain worlds  $y_0, \dots, y_{k-1}, z_0, \dots, z_{k-1}$  as required.  $\blacksquare$

LEMMA 10. *For any  $0 < k < \omega$ ,  $\mathfrak{F}_k \not\models \mathbf{K}^\alpha$ .*

**Proof.** By Claims 8 and 9, it is enough to show that  $\Phi_k$  fails in  $\mathfrak{F}_k$ . To this end, take the following ‘fork’ in  $\mathfrak{F}_k$ :

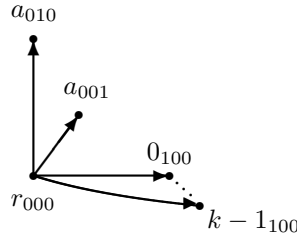

that is, let  $v = r_{000}$ ,  $y = a_{010}$ ,  $z = a_{001}$ , and  $x_i = i_{100}$  for  $i < k$ . Now the only points in  $\mathfrak{F}_k$  suitable for  $u$  are  $i_{011}$ , for all  $i < k$ . We will show that none of them can be ‘extended’ with other points as required. To this end, fix some  $i < k$  and let  $u = i_{011}$ . On the one hand, the only points in  $\mathfrak{F}_k$  suitable for  $u_i$  are  $i_{111}^1$  and  $i_{111}^2$ . On the other, the only points in  $\mathfrak{F}_k$  suitable for  $y_i$  and  $z_i$  are  $i_{110}$  and  $i_{101}$ , respectively. But  $(i_{101}, i_{111}^1) \notin R_1^{\mathfrak{F}}$  and  $(i_{110}, i_{111}^2) \notin R_2^{\mathfrak{F}}$ .  $\blacksquare$

**Acknowledgement.** I am grateful to Rob Goldblatt for his careful reading of the preliminary version and for his suggestions.

## BIBLIOGRAPHY

- [1] H. Andr eka. Complexity of equations valid in algebras of relations. Part I: strong non-finitizability. *Annals of Pure and Applied Logic*, 89:149–209, 1997.
- [2] D.M. Gabbay, A. Kurucz, F. Wolter, and M. Zakharyashev. *Many-Dimensional Modal Logics: Theory and Applications*, volume 148 of *Studies in Logic and the Foundations of Mathematics*. Elsevier, 2003.
- [3] D.M. Gabbay and V. Shehtman. Products of modal logics. Part I. *Journal of the IGPL*, 6:73–146, 1998.
- [4] L. Henkin, J.D. Monk, and A. Tarski. *Cylindric Algebras, Part II*, volume 115 of *Studies in Logic and the Foundations of Mathematics*. North Holland, 1985.
- [5] R. Hirsch, I. Hodkinson, and A. Kurucz. On modal logics between  $\mathbf{K} \times \mathbf{K} \times \mathbf{K}$  and  $\mathbf{S5} \times \mathbf{S5} \times \mathbf{S5}$ . *Journal of Symbolic Logic*, 67:221–234, 2002.
- [6] J.S. Johnson. Nonfinitizability of classes of representable polyadic algebras. *Journal of Symbolic Logic*, 34:344–352, 1969.

- [7] A. Kurucz. On axiomatising products of Kripke frames. *Journal of Symbolic Logic*, 65:923–945, 2000.
- [8] A. Kurucz. Combining modal logics. In P. Blackburn, J. van Benthem, and F. Wolter, editors, *Handbook of Modal Logic*, volume 3 of *Studies in Logic and Practical Reasoning*, pages 869–924. Elsevier, 2007.
- [9] J.D. Monk. Nonfinitizability of classes of representable cylindric algebras. *Journal of Symbolic Logic*, 34:331–343, 1969.
- [10] K. Segerberg. Two-dimensional modal logic. *Journal of Philosophical Logic*, 2:77–96, 1973.
- [11] V. Shehtman. Two-dimensional modal logics. *Mathematical Notices of the USSR Academy of Sciences*, 23:417–424, 1978. (Translated from Russian).

Agi Kurucz

Department of Computer Science  
King's College London  
Strand, London WC2R 2LS, U.K.  
agi.kurucz@kcl.ac.uk